

14 H.P. 38" Lawn Tractor

---

# Operating Manual

---

Model No. TMO-33934A

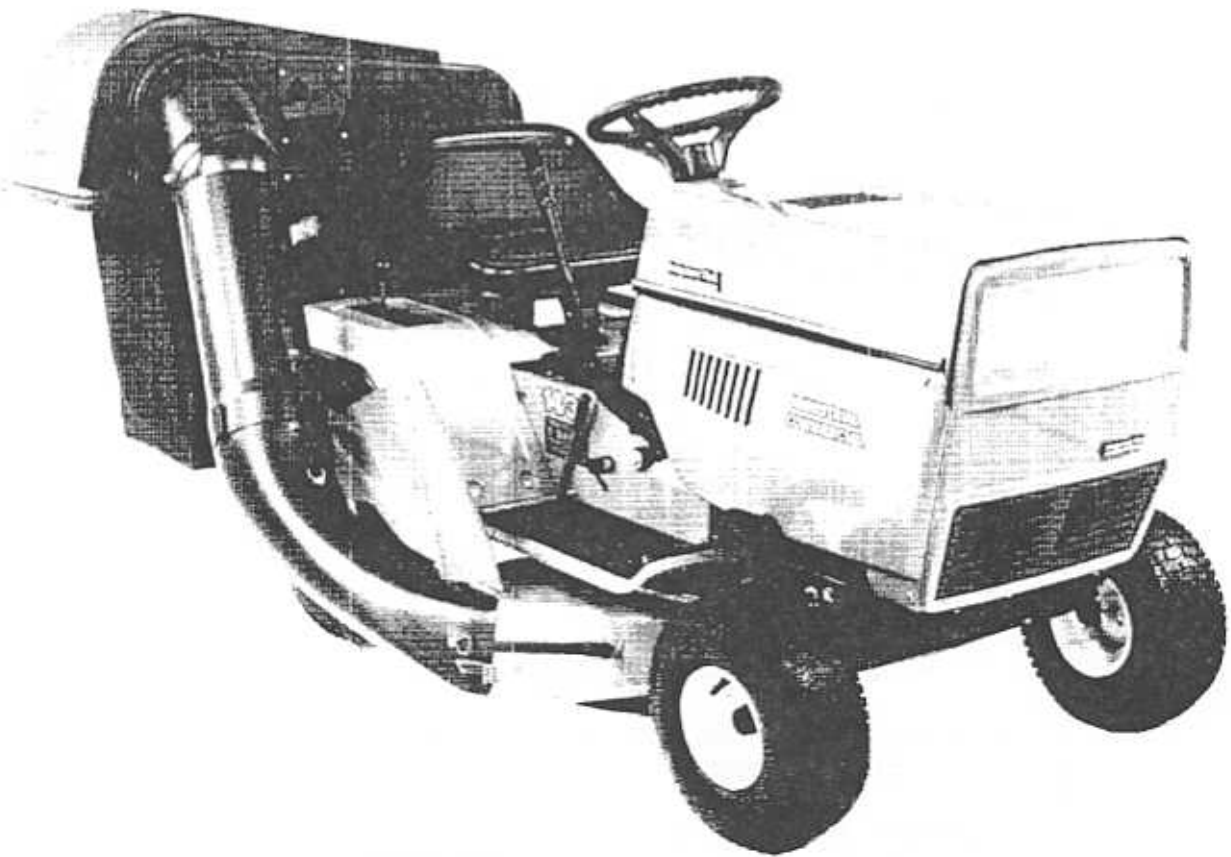

(Shown With Optional Grass Collector)

---

**Montgomery Ward**

---

# INDEX

Slope Gauge .....	3
Contents of Hardware Pack .....	4
Rules for Safe Operation .....	5
Assembly Instructions .....	6
Controls .....	10
Operation .....	12
Adjustments .....	14
Lubrication .....	16
Maintenance .....	17
Off-Season Storage .....	20
Trouble Shooting Chart .....	21, 22
Electrical System .....	23
Illustrated Parts for Lawn Tractor .....	24-33
Illustrated Parts for Transaxle .....	34, 35
Parts Information .....	Back Cover

Dear Customer,

So often throughout the year we are all in a rush to meet our daily obligations.

However, we at Montgomery Ward are taking a quick moment out to say...

**"Thank you for your business."**

Sincerely,  
MONTGOMERY WARD



**INSTRUCTIONS GIVEN WITH THIS SYMBOL ARE FOR PERSONAL SAFETY. BE SURE TO FOLLOW THEM.**

**NOTICE:** A data plate with the model number and serial numbers of your unit is located on the frame, under the seat. Record these number in the spaces provided on the back cover of this guide.

## BEFORE YOU CALL SERVICE

### Check Spark Plug Wire

- Firmly attached?
- Wire terminal clean?

### Check Crankcase Oil Level

- Overfilled/underfilled?

### Check Fuel Tank

- Fuel in tank?
- Fuel dirty or stale?
- If tank has been empty for a long period, fill tank completely.

### Check Air Cleaner

- Clean?
- Choke plate stuck?
- Governor spring free to move?

### Check under Blade Housing (Disconnect Spark Plug First)

- Blade obstructed or bent?

### Check Starting Instructions

- Read instruction manuals and labels for specific instructions.

**WARNING:** This unit is equipped with an internal combustion engine and should not be used on or near any unimproved forest-covered, brush-covered or grass-covered land unless the engine's exhaust system is equipped with a spark arrester meeting applicable local or state laws (if any). If a spark arrester is used, it should be maintained in effective working order by the operator.

In the State of California the above is required by law (Section 4442 of the California Public Resources Code). Other states may have similar laws. Federal laws apply on federal lands. A spark arrester for the muffler is available through your nearest engine authorized service center.

Cut Along This Line

USE THIS SHEET AS A GUIDE TO DETERMINE SLOPES WHERE YOU MAY NOT OPERATE SAFELY.

# SLOPE GAUGE

(Keep this sheet in a safe place for future reference.)

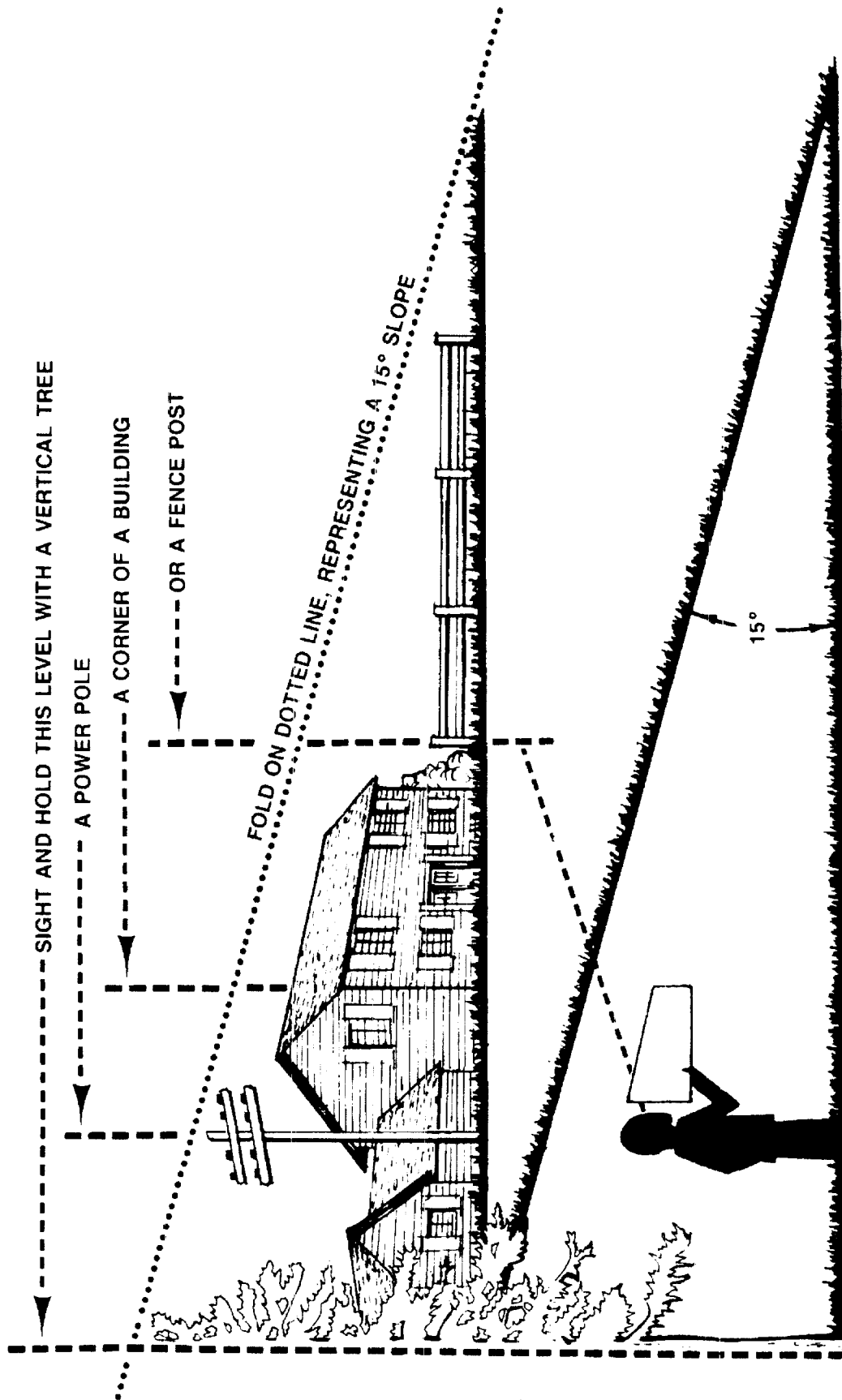

Do not mow on inclines with a slope in excess of 15 degrees (a rise of approximately 2½ feet every 10 feet). A riding mower could overturn and cause serious injury. If operating a walk-behind mower on such a slope, it is extremely difficult to maintain your footing and you could slip, resulting in serious injury.

Operate RIDING mowers up and down slopes, never across the face of slopes.

Operate WALK-BEHIND mowers across the face of slopes, never up and down slopes.

# CONTENTS OF HARDWARE PACK

Remove this sheet from your owner's manual and lay the hardware on the illustration for identification purposes. Refer to the separate deck manual for any assembly instructions concerning the deck and additional contents of hardware pack (if any). After assembly, keep the Slope Gauge which is on the reverse side of this sheet for future use.

(Hardware pack may contain extra items which are not used on your unit.)

## A ATTACHING THE STEERING WHEEL

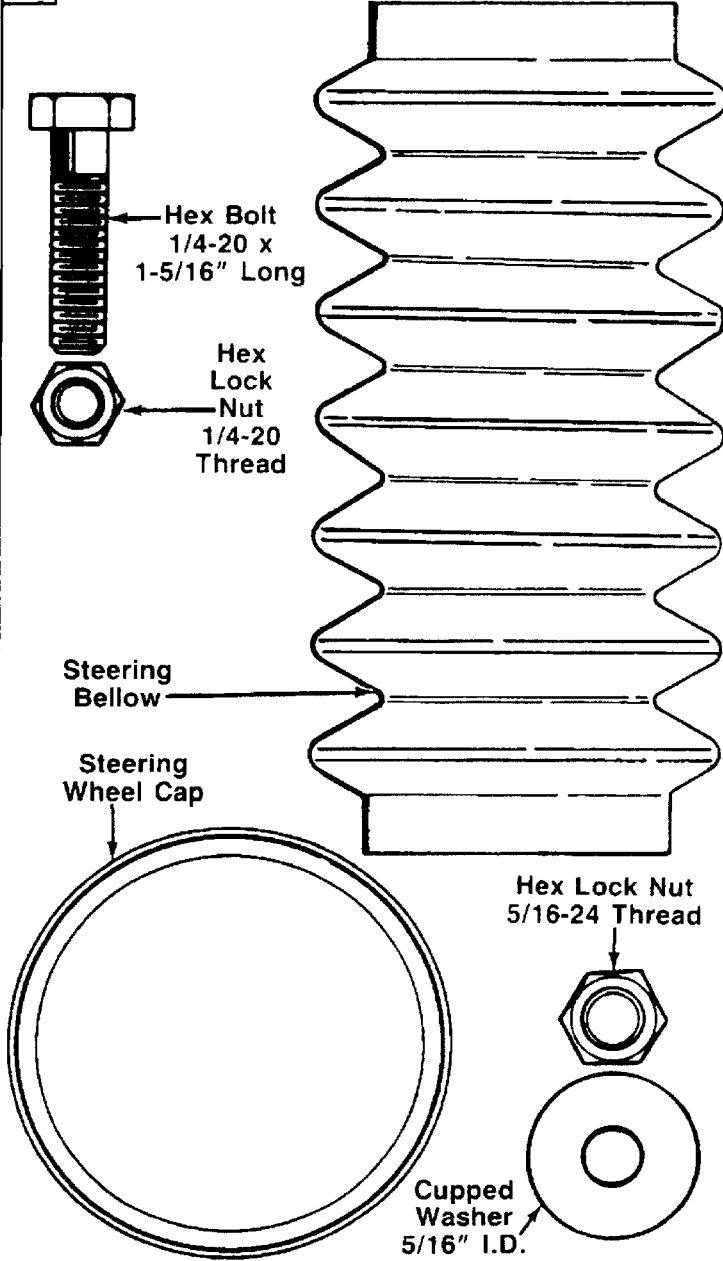

## C INSTALLING THE BATTERY (Black Plastic Battery Cover is Not Shown)

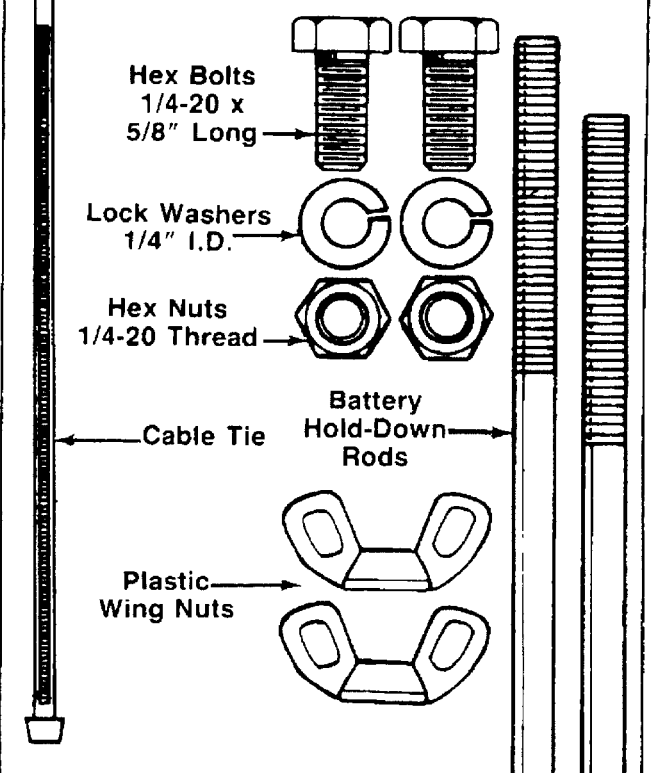

## D ATTACHING THE HITCH BAR

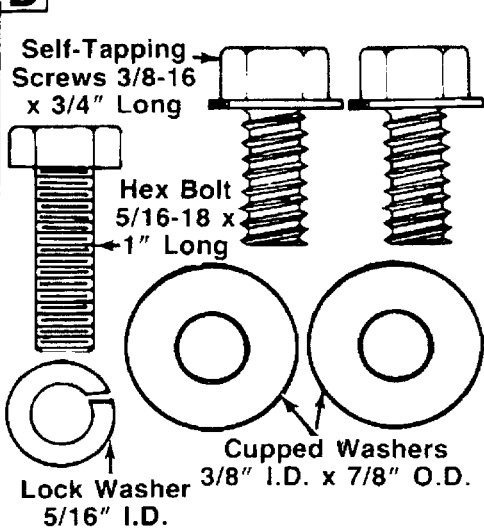

## B ATTACHING THE SEAT

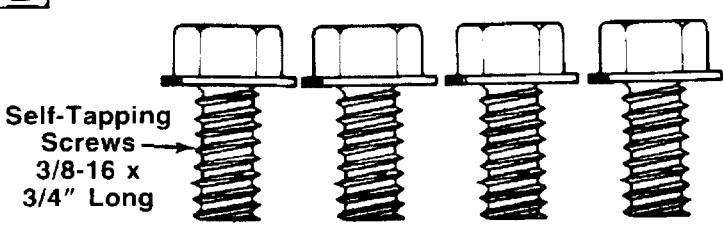



**E IGNITION KEYS**  
Not Shown  
(May Be Attached  
to Tractor)



# IMPORTANT

## RULES FOR SAFE OPERATION



THIS SYMBOL POINTS OUT IMPORTANT SAFETY INSTRUCTIONS WHICH, IF NOT FOLLOWED, COULD ENDANGER THE PERSONAL SAFETY AND/OR PROPERTY OF YOURSELF AND OTHERS. READ AND FOLLOW ALL INSTRUCTIONS IN THIS MANUAL BEFORE ATTEMPTING TO OPERATE YOUR UNIT. FAILURE TO COMPLY WITH THESE INSTRUCTIONS MAY RESULT IN PERSONAL INJURY. WHEN YOU SEE THIS SYMBOL—  **HEED ITS WARNING.** 





Your unit was built to be operated according to the rules for safe operation in this manual. As with any type of power equipment, carelessness or error on the part of the operator can result in serious injury. If you violate any of these rules, you may cause serious injury to yourself or others.

1. READ THIS OWNER'S MANUAL carefully in its entirety before attempting to assemble or operate this unit. Keep this manual in a safe place for future and regular reference and for ordering replacement parts.
  2. This unit is a precision piece of power equipment, not a plaything. Therefore exercise extreme caution at all times.
  3. Know the controls and how to stop the machine quickly.
  4. Do not allow children to operate vehicle. Do not allow adults to operate it without proper instruction. Only persons well acquainted with these rules of safe operation should be allowed to use your mower.
  5. Wear sturdy, rough-soled work shoes and close-fitting slacks and shirts to avoid entanglement in the moving parts. Never operate a unit in bare feet, sandals, or sneakers.
  6. To prevent injury, do not carry passengers or give rides. Keep children, pets and bystanders out of the area while mowing. Only the operator should ride on the unit and only ride in the seat.
  7. Check overhead clearance carefully before driving under power lines, guy wires, bridges or low hanging tree branches, before entering or leaving buildings, or in any other situation where the operator may be struck or pulled from the unit, which could result in serious injury.
  8. To maintain control of the unit and reduce the possibility of upset or collision, operate the tractor smoothly. Avoid erratic operation and excessive speed.
  9. Keep the area of operation clear of all persons, particularly small children and pets. Stop engine when they are in the vicinity of your mower. Although the area of operation should be completely cleared of foreign objects, a small object may have been overlooked and could be accidentally thrown by the mower in any direction and cause injury to you or a bystander.
  10. Stop the blade(s) when crossing gravel drives, walks or roads.
  11. Disengage all attachment clutches and shift into neutral before attempting to start engine.
  12. Disengage power to attachment(s) and stop engine before leaving operating position.
  13. Do not put hands or feet near or under rotating parts. Keep clear of the discharge opening at all times as the rotating blade(s) can cause injury.
  14. Disengage power to attachment(s) and stop engine before making any repairs or adjustments. Disconnect the spark plug wire and keep the wire away from the plug to prevent accidental starting.
15. Before attempting to unclog the mower or discharge chute, stop the engine. The mower blade(s) may continue to rotate for a few seconds after the engine is shut off. Therefore, be sure the blade(s) have stopped completely. Disconnect the spark plug wire and keep the wire away from the plug to prevent accidental starting.
  16. Disengage power to attachment(s) when transporting or not in use.
  17. Take all possible precautions when leaving vehicle unattended such as disengaging power take-off, lowering attachments, shifting into neutral, setting parking brake, stopping engine and removing key.
  18. For your safety, use the slope gauge included as part of this manual to measure slopes before operating this unit on a sloped or hilly area. If the slope is greater than 15° as shown on the slope gauge, do not operate this unit on that area or serious injury could result.
  19. Do not stop or start suddenly when going uphill or downhill. Mow up and down face of steep slopes; never across the face. Use extreme caution if it is necessary to drive the tractor up an incline or back the tractor down an incline because the front of the tractor could lift and rapidly flip over backward which could cause serious injury.
  20. Reduce speed on slopes and in sharp turns to prevent tipping or loss of control. Always keep the tractor in gear when going down steep hills to take advantage of engine braking action.
  21. Stay alert for holes in terrain and other hidden hazards which may cause the unit to tip over.
  22. Use care when pulling loads or using heavy equipment.
    - A. Use only approved drawbar hitch points.
    - B. Limit loads to those you can safely control.
    - C. Do not turn sharply. Use care when backing.
    - D. Use counterweight(s) or wheel weights when suggested in owner's manual.
  23. Watch out for traffic when crossing or near roadways.
  24. When using any attachments, never direct discharge of material toward bystanders nor allow anyone near vehicle while in operation.
  25. Handle gasoline with care. It is highly flammable.
    - A. Use approved gasoline container.
    - B. Never remove cap or add gasoline to a running or hot engine or fill fuel tank indoors. Wipe up spilled gasoline.
    - C. Open doors if engine is run in garage. Exhaust fumes are dangerous. Do not run engine indoors.

## Rules for Safe Operation (continued)

26. Keep the vehicle and attachments in good operating condition, and keep safety devices in place. Use guards as instructed in operator's manual.
27. Keep all nuts, bolts, and screws tight to be sure the equipment is in safe working condition.
28. Never store the machine with fuel in the fuel tank inside a building where ignition sources are present, such as hot water and space heaters, clothes dryers, and the like. Allow the engine to cool before storing in any enclosure.
29. To reduce fire hazard, keep engine free of grass, leaves or excessive grease.
30. The vehicle and attachments should be stopped and inspected for damage after striking a foreign object. The damage should be repaired before restarting and operating the equipment.
31. Do not change the engine governor settings or overspeed the engine.
32. When using the vehicle with mower, proceed as follows:
  - (1) Mow only in daylight or in good artificial light.
  - (2) Never make a cutting height adjustment while engine is running if operator must dismount to do so.
  - (3) Shut the engine off and wait until the blade comes to a complete stop before removing the grass catcher.
  - (4) Check blade mounting bolts for proper tightness at frequent intervals.
33. Check grass catcher bags frequently for wear or deterioration. For safety protection, replace only with new bag meeting original equipment specifications.
34. Look behind to make sure the area is clear before placing the transmission in reverse and continue looking behind while backing up. Disengage blades before shifting into reverse and backing up.
35. This unit should not be driven up a ramp onto a trailer or truck under power, because the unit could tip over, causing serious personal injury. The unit must be pushed manually to load properly.

 **IMPORTANT:** This unit is shipped **WITHOUT GASOLINE** or **OIL**; however, a small amount of oil may be present from the factory. Do not overfill. After assembly, service engine with gasoline and oil as instructed in the separate engine manual packed with your unit.

 **NOTE:** Reference to right or left hand side of the unit is observed from the driver's seat, facing forward.

## ASSEMBLY

### UNPACKING

1. Remove the lawn tractor from the carton as follows. Open the top flaps. Remove all loose parts and carton inserts. Cut the front corners of the carton. Make certain brake is released, and push the unit out of the carton.
2. Remove page four from this manual and lay the contents of the hardware pack on the illustration for identification.

 **NOTE**

Two mounting brackets and hardware are included in a separate bag for use with the optional rear bagging kit, stock number 89-35108R. Keep these parts in a safe place for future use.

### BATTERY INFORMATION



- A. Battery acid must be handled with great care as contact with it can burn and blister the skin. It is also advisable to wear protective clothing (goggles, rubber gloves and apron) when working with it.\*
- B. Should battery acid accidentally splatter into the eyes or onto the face, rinse the affected area immediately with clean, cold water. If there is any further discomfort, seek prompt medical attention.
- C. If acid spills on clothing, first dilute it with clean water, then neutralize with a solution of ammonia/water or baking soda/water.
- D. Since battery acid is corrosive, do not pour it into any sink or drain. Before discarding empty electrolyte containers, rinse them with a neutralizing solution.
- E. NEVER connect or disconnect charger clips to battery while charger is turned on as it can cause sparks.
- F. Keep all lighted materials (cigarettes, matches, lighters) away from the battery as the hydrogen gas generated during charging can be combustible.
- G. As a further precaution, only charge the battery in a well-ventilated area.

**\*Always shield eyes, protect skin and clothing when working near batteries.**

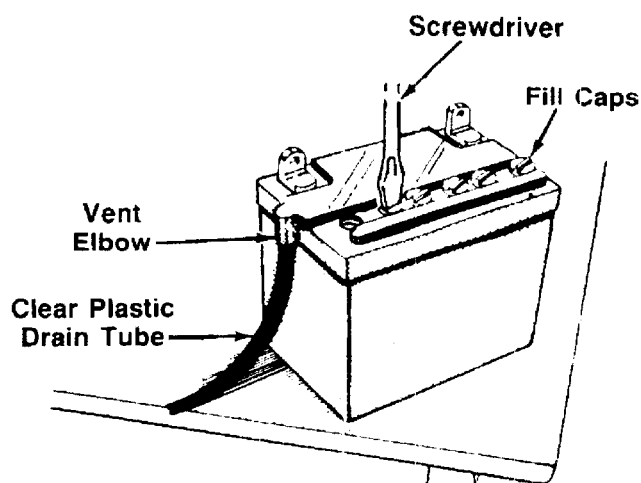

FIGURE 1.

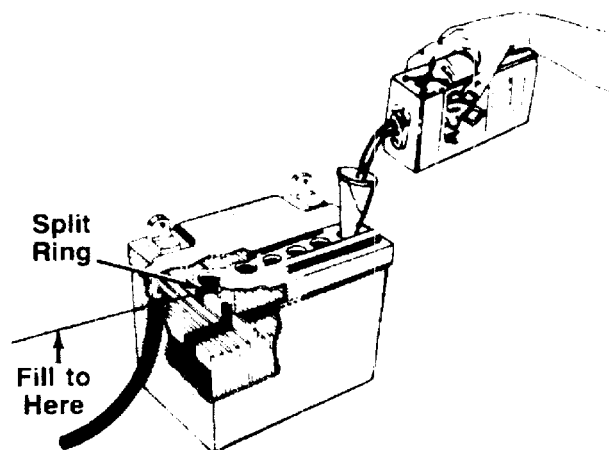

FIGURE 2.

### ACTIVATING THE BATTERY

Do not activate battery (fill with battery acid) until battery is actually placed in service. Be certain to read previous warnings before activating the battery.

1. Open the battery pack. Be careful not to puncture the box. It contains the battery with a long plastic tube attached, battery fluid (acid) in a cardboard container and one cone.
2. Place the battery on a table or workbench. Make certain the long plastic drain tube is in place on the vent elbow.
- ← 3. Remove the six fill caps from the top of the battery with a screwdriver. Be careful not to damage the fill caps. See figure 1.
4. Cut off the tip of the cone for use as a funnel.
5. Place the battery fluid container upright on the table or workbench. Carefully remove the flap on the box, and pull out the plastic tube. Cut off the tip of the plastic tube. Do not squeeze the container when cutting the tip.
- ← 6. Fill each battery cell slowly and carefully to the split ring at the bottom of the well. See figure 2. Use caution as the acid level will rise rapidly after the bottom of the cell is filled. **DO NOT OVERFILL.**
7. Allow battery to stand for 30 minutes with the fill caps removed, while the plates absorb acid.
8. If acid level has fallen after the 30 minute standing period, refill each cell with battery acid to the split ring. Replace the fill caps.
9. Before discarding the empty container, neutralize any residue with baking soda and rinse container with water. Puncture container several times before discarding.
0. Charge the battery after the 30 minute standing period. **SLOW CHARGE THE BATTERY (DO NOT FAST CHARGE)** at a maximum bench rate of 5 amperes until the specific gravity reading is 1.265 (Approximately 30 minutes).



**DANGER**

Battery contains sulfuric acid. Refer to warning on page 6. Antidote: EXTERNAL—Flush with water. INTERNAL—Drink large quantities of water or milk. Follow with milk of magnesia, beaten egg or vegetable oil. Seek prompt medical attention. EYES: Flush with cool water for at least 15 minutes, then seek immediate medical attention.

Since batteries produce explosive gases, keep all lighted materials (cigarettes, lighters, matches, etc.) away. Be sure to charge battery only in well-ventilated areas.

KEEP BATTERIES  
OUT OF THE REACH OF CHILDREN

➡ **NOTE**

After battery has been in service, add only distilled water to replace normal loss. Do not add acid.

➡ **NOTE**

This engine is equipped with an alternator. The current for the battery charger alternator is unregulated. During normal operation, it is only necessary to charge the battery:

1. When it is activated for the first time
2. Before winter storage.
3. Before using the lawn tractor after winter storage.

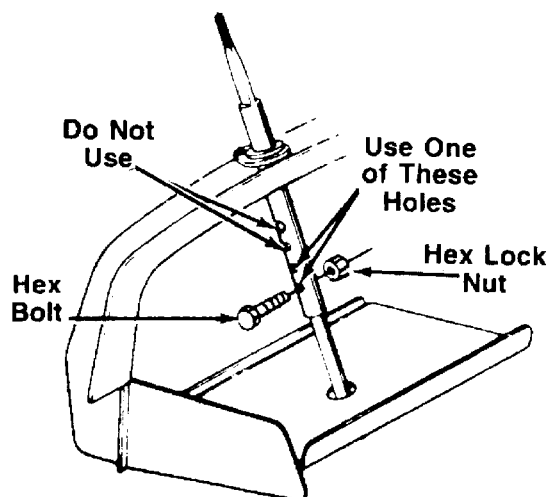
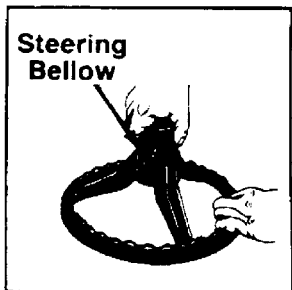
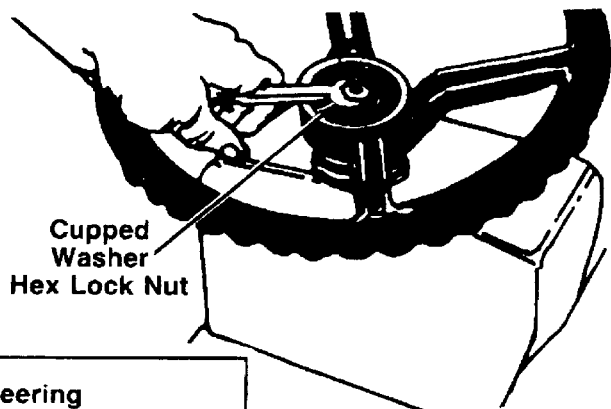

FIGURE 3.

### ATTACHING THE STEERING WHEEL (Hardware A)

1. For shipping purposes, the upper steering shaft is pushed all the way down over the lower steering shaft. Pull the upper steering shaft up. The holes in the shaft provide steering wheel height adjustment. When securing the two halves of the steering shaft, select one of the two lower holes in the upper shaft as shown. **Do not** use the two upper holes. Secure with hex bolt and hex lock nut. See figure 3.



2. Attach one end of steering bellow to the steering wheel as shown in figure 4, inset.
3. Position the front wheels of the tractor so they are pointing straight forward.
4. Place the steering wheel and steering bellow over the steering shaft, positioning steering wheel as desired.
5. Place the washer with the cupped side down over the steering shaft. Secure with 5/16" hex lock nut. See figure 4.
6. Place the steering wheel cap over the center of the steering wheel and seat it with your hand.



FIGURE 4.

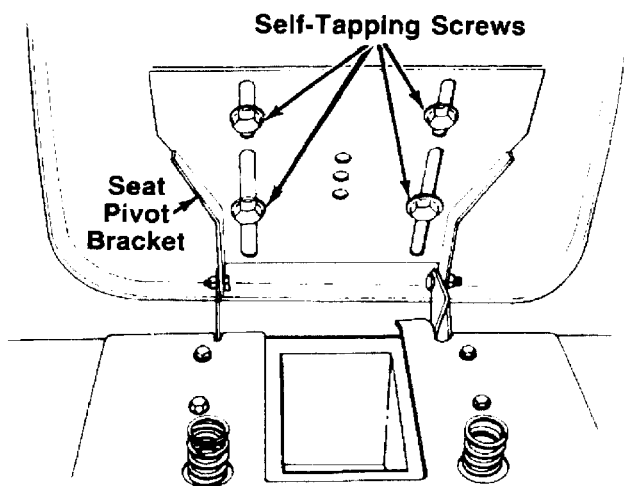
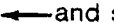

FIGURE 5.

### ATTACHING THE SEAT (Hardware B)

Place the seat in position against the seat pivot bracket, lining up the slotted holes in the pivot bracket with the holes in the seat. Select desired position for the seat, and secure with self-tapping screws. See figure 5.





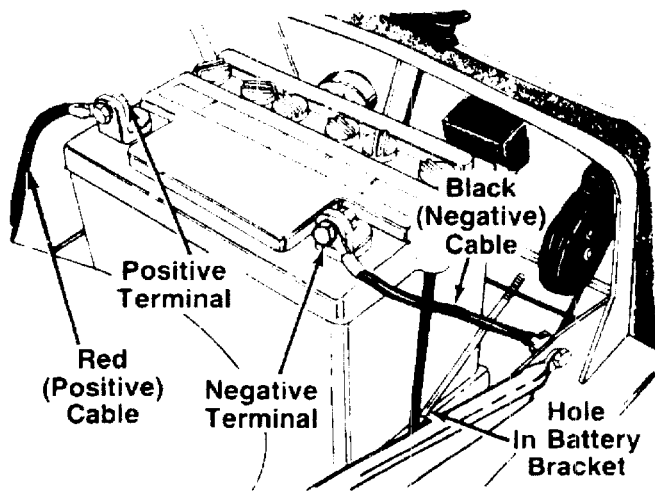

FIGURE 6.

### INSTALLING THE BATTERY (Hardware C)

1. Open the hood of the lawn tractor by lifting up on both sides of the hood.
2. Place the battery in the lawn tractor so that the positive terminal is facing the right side of the unit. See figure 6.

**NOTE**

Right and left hand sides of the unit are determined from the operating position, facing forward.

3. Attach the positive cable (heavy red wire) to the positive battery terminal (+) with hex bolt 5/8" long, 1/4" lock washer and hex nut. See figure 6.
4. Attach the negative cable (heavy black wire) to the negative battery terminal (-) with the other hex bolt 5/8" long, 1/4" lock washer and hex nut.

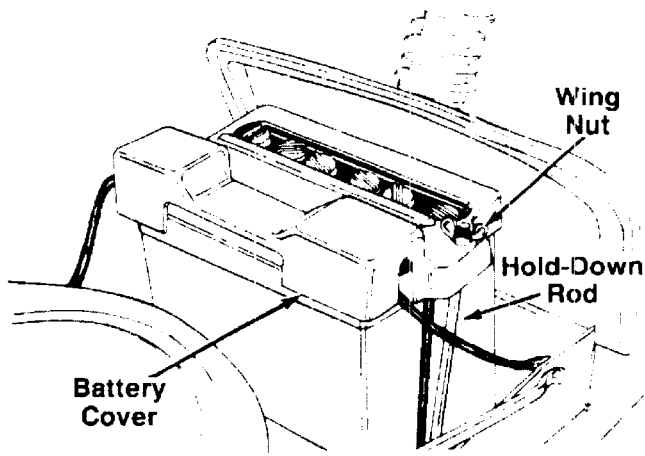

FIGURE 7.

5. Hook one hold-down rod into the hole in the edge of the battery bracket beside the battery. See figure 6. Place the black plastic battery cover in position over the hold-down rod. Secure with wing nut. Attach other hold-down rod to the other side of battery cover in the same manner. See figure 7.

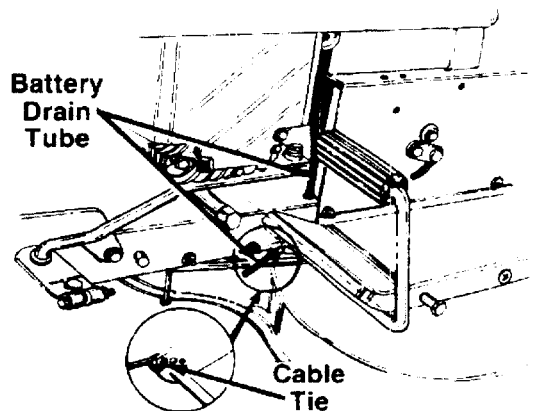

FIGURE 8.

6. Route the battery drain tube down through the hole in the frame, then forward to the bracket on clutch-brake pedal shaft. See figure 8.

7. Secure drain tube to bracket on clutch-brake pedal shaft, using the cable tie. Trim excess end of cable tie.

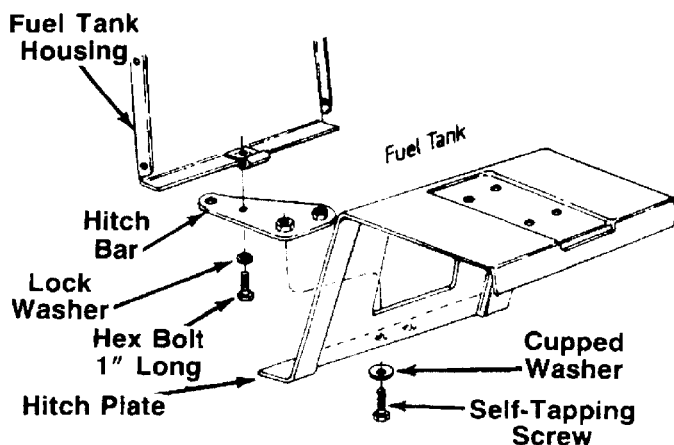

FIGURE 9.

#### ATTACHING THE HITCH BAR (Hardware D)

1. Place the hitch bar (weld nuts up) above the edge of the hitch plate on the tractor. See figure 9. Secure with two 3/4" long self-tapping screws and cupped washers (cupped side of washers go against the hitch plate).
2. Attach the hitch bar to the speed nut on the edge of the fuel tank housing using hex bolt 1" long and lock washer.

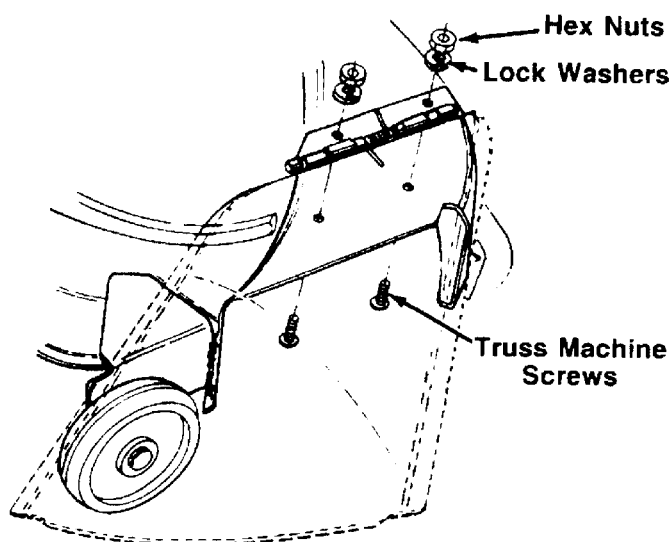

FIGURE 10.

#### ATTACHING THE CHUTE DEFLECTOR (If Unassembled)

If the chute deflector has not been assembled on your unit, remove the truss machine screws, lock washers and hex jam nuts which are attached to the deck next to the chute opening.

- ← Place the chute deflector in position as shown in figure 10. Secure with hardware just removed.



**WARNING**

Do not operate your unit unless the chute deflector has been properly installed.

## CONTROLS

### THROTTLE CONTROL

The throttle control is used to regulate the engine speed. To get maximum efficiency from cutting, the throttle should be in the FAST position when operating the mower. See figure 11.

### CHOKE CONTROL

The choke control is located on the dashboard and is operated manually. Details for the choke operation are covered in the separate engine manual packed with your unit. See figure 11.

### SHIFT LEVER

The shift lever is located on the left side of the console and has three positions, FORWARD, NEUTRAL and REVERSE. See figure 11. The clutch-brake pedal must be depressed and the lawn tractor must not be moving when shifting gears. Do not force the shift lever.

Release the clutch-brake pedal slightly to line up the shifting collar in the transmission. Then try to shift gears.

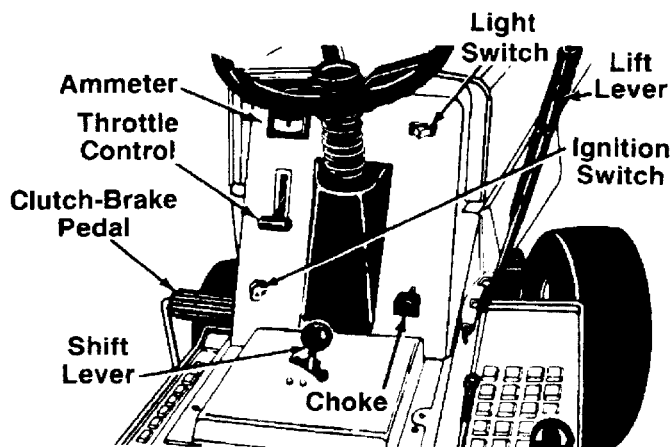

FIGURE 11.

## SPEED CONTROL LEVER

The speed control lever is located on the right fender. It allows you to regulate the ground speed of the lawn tractor. See figure 12. To select the ground speed, depress clutch pedal. Push speed control lever outward and move backward to slow lawn tractor, move forward to increase speed. When desired speed has been obtained, release lever in that position. Whenever clutch is engaged, unit will automatically go to the pre-set speed.

## IGNITION SWITCH

Turn the key to the START position to start the engine. When the engine is running, let the key return to the ON position. To stop the engine, turn the key to the left to the OFF position and remove it to prevent accidental starting. See figure 11.

## LIGHT SWITCH

Push the light switch to turn on the lights. The lights will only operate when the engine is running. See figure 11.

## AMMETER

The ammeter registers the rate of battery charge or discharge. The ammeter will register on the discharging side when starting the engine. It should register on the opposite side (charging) when the engine is running in the fast position until the battery is completely charged. With a fully charged battery or with the engine idling, the ammeter will not show a charge. See figure 11.

## CLUTCH-BRAKE PEDAL

The clutch-brake pedal is located on the left side of the lawn tractor. Depressing the clutch-brake pedal part way disengages the clutch. Pressing the pedal all the way down disengages the clutch and engages the disc brake. See figure 11.

### ➡ NOTE

The clutch-brake pedal must be depressed to start the engine.

## PARKING BRAKE

The speed control lever is used to set the parking brake. To set the parking brake, depress the clutch-brake pedal. Press the speed control lever outward and all the way to the rear of the unit. Release the speed control lever and the clutch-brake pedal.

To release the parking brake, depress the clutch-brake pedal, press the speed control lever outward and move to desired position. Release the speed control lever and the clutch-brake pedal.

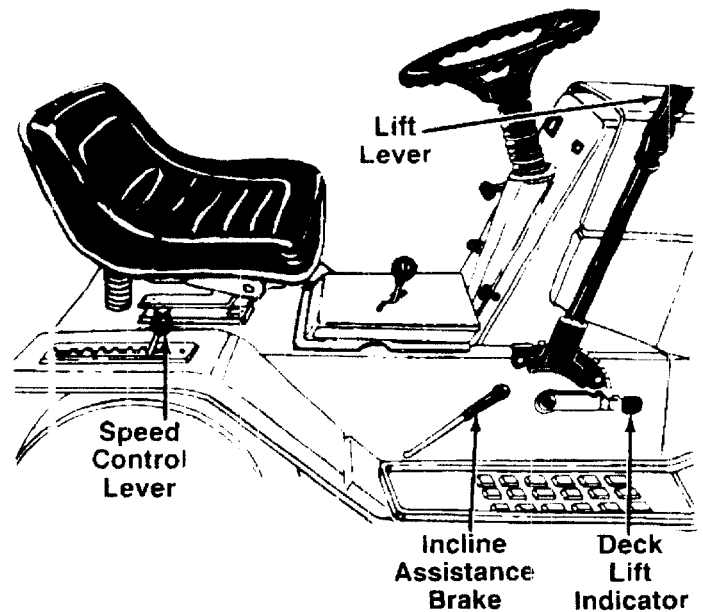

FIGURE 12.

## INCLINE ASSISTANCE BRAKE

When stopping on a hill, hold the incline assistance brake lever back while you release the clutch-brake pedal until the lawn tractor begins to move, then release the lever. This lever permits smoother starts and clutch engagement by holding the tractor during the brake release/clutch engagement operation. See figure 12.

## INTERLOCKS (Not Shown)

Interlock safety switches are located on the clutch-brake pedal, lift lever, the shift lever and under the seat.

Before the engine will start, the clutch-brake pedal must be depressed all the way and the lift lever must be in the disengaged position.

Before the unit can be shifted into reverse or if the operator leaves the seat, lift lever must be in the disengaged position.

## LIFT LEVER

The lift lever is used to raise and lower the cutting deck and to engage and disengage the cutting blades. Pulling it all the way back and locking it disengages the blades. The lift lever must be in the disengaged position when starting the engine, when shifting into reverse or if the operator leaves the seat.

## DECK LIFT INDICATOR

The deck lift indicator marks the position being used for the lift lever. Select the lift lever position desired, press the indicator lever outward, move it to the position immediately below the lift lever and release the indicator lever. See figure 12.

## DECK WHEEL HEIGHT ADJUSTMENT

Move the deck wheel to the desired hole location in the deck.

## SETTING THE CUTTING HEIGHT

1. Select the position for the lift lever which gives the desired cutting height. Move the deck lift indicator so that the lift lever can be returned to the same position after it is raised.
2. Set the deck wheels so that the wheels are  $\frac{1}{4}$  to  $\frac{1}{2}$  inch above the ground.

## OPERATION

### CAUTION

- READ OPERATOR'S MANUAL(S) • NEVER CARRY CHILDREN
- KNOW LOCATION AND FUNCTION OF ALL CONTROLS
- KEEP SAFETY DEVICES (GUARDS, SHIELDS AND SWITCHES) IN PLACE AND WORKING
- REMOVE OBJECTS THAT COULD BE THROWN BY BLADE(S)
- DO NOT OPERATE THE UNIT WHEN CHILDREN AND OTHERS ARE AROUND
- ALWAYS LOOK BEHIND THE UNIT BEFORE BACKING UP
- DO NOT OPERATE THE UNIT WHERE IT COULD SLIP OR TIP
- IF THE UNIT STOPS GOING UPHILL, STOP BLADE(S) AND BACK SLOWLY DOWNHILL
- BE SURE BLADE(S) AND ENGINE ARE STOPPED BEFORE PLACING HANDS OR FEET NEAR BLADE(S)
- BEFORE LEAVING OPERATOR'S POSITION, SHUT ENGINE OFF AND REMOVE KEY

### TIRE PRESSURE

For shipping purposes, the tires on your unit may be over-inflated. Tire pressure should be reduced before unit is put into operation. Recommended operating tire pressure should be 10 p.s.i.

Check sidewall of tire for manufacturer's maximum tire pressure. If this information does not appear on your tire, maximum tire pressure under any circumstances is 30 p.s.i. Equal tire pressure should be maintained on all tires.

### STARTING THE ENGINE

#### NOTE

To open the hood, simply lift up on both sides of the hood.

1. Service the engine with oil and gasoline as described in the engine manual.
2. Depress the clutch-brake pedal and set the parking brake.
3. Place the lift lever in the DISENGAGED position. See figure 12.

#### NOTE

This unit is equipped with a **safety interlock system** for your protection. The purpose of the safety interlock system is to prevent the engine from cranking or starting unless the clutch-brake pedal is depressed and the lift lever is in the disengaged position. In addition, the lift lever must be in the disengaged position when the unit is put into reverse or the engine will shut off. If the operator leaves the seat with the lift lever engaged, the engine will shut off.



Do not operate the lawn tractor if the interlock system is malfunctioning because it is a safety device, designed for protection.

4. Set the throttle control in the FAST position. See figure 11.
5. Pull choke knob to choke engine.

#### NOTE

A warm engine may not require choking.

6. Turn the ignition key to the START position. When the engine is running, let the key return to the ON position. See figure 11.
7. Push choke knob in gradually. Move the throttle control to desired engine speed.

### STOPPING THE ENGINE

Turn the ignition key to the left to the OFF position. Remove the key to prevent accidental starting.

#### NOTE

A brief break-in period is essential to ensure maximum engine and mower life. The break-in consists of running the engine at half speed for a period of time required to use one tank of gasoline. It is also recommended to change crankcase oil after the first 5 hours of operation.

Be sure that the lawn is clear of stones, sticks, wire, or other objects which could damage lawn tractor or engine. For best results and to insure more even grass distribution, do not mow when lawn is excessively wet.

 **IMPORTANT**

If you strike a foreign object, stop the engine. Remove wire from spark plug, thoroughly inspect the unit for any damage, and repair the damage before restarting and operating the mower.

 **NOTE**

If any problems are encountered, refer to the Trouble Shooting Chart on page 21.

**OPERATING THE LAWN TRACTOR**

1. Set the desired cutting height.
2. Start the engine as instructed on previous page 12.
3. Move throttle control to  $\frac{3}{4}$  or full throttle to prevent strain on the engine and to operate the cutting blades.
4. Place the shift lever in either the FORWARD or REVERSE position.



**CAUTION**

Look to the rear before backing up.

5. Release the parking brake by depressing the clutch-brake pedal, pressing outward on the speed control lever and moving to desired position.

 **NOTE**

Use first speed position when operating the lawn tractor for the first time.

6. Release clutch-brake pedal slowly to put unit into motion.
7. The lawn tractor is brought to a stop by depressing the clutch-brake pedal.

 **NOTE**

When operating the unit initially, there will be little difference between the highest two speeds until after the belts have seated themselves into the pulleys during the break-in period.



**CAUTION**

If the unit is not to be used for a long period, place the gear shift lever in NEUTRAL, stop the engine, set the parking brake and remove the key. DO NOT leave the machine on an incline.

If unit stalls with speed control in high speed, or if unit will not operate with speed control lever in a low speed position, proceed as follows.

1. Place shift lever in NEUTRAL.
2. Restart engine.
3. Place speed control lever in high speed position.
4. Release clutch-brake pedal fully.
5. Depress clutch-brake pedal.
6. Place speed control lever in desired position.
7. Place shift lever in either FORWARD or REVERSE, and follow normal operating procedures.

**OPERATING THE CUTTING BLADES**

The cutting blades may be engaged while the lawn tractor is moving or standing still. DO NOT engage the cutting blades abruptly as the sudden belt tension on the pulley may cause the engine to stall.



When the blade drive is engaged, keep feet and hands away from the discharge opening, the blades or any part of the deck.

Move the lift lever into the DISENGAGED position to disengage the blades.

 **NOTE**

When the machine is used for other than mowing operations, the blade drive should be disengaged.

GRASS COLLECTOR Stock Number 89-35108R is available as optional equipment for the lawn tractor shown in this manual.



The mower should not be operated without the entire grass catcher or chute deflector in place.

 **NOTE**

Under normal usage bag material is subject to wear, and should be checked periodically. Be sure any replacement bag complies with the mower manufacturer's recommendations.

For replacement bags, use only factory authorized replacement bag.

# ADJUSTMENTS

## SEAT ADJUSTMENT

The seat may be adjusted to different positions. Refer to "Attaching the Seat" section of Assembly Instructions.

## STEERING WHEEL ADJUSTMENT

There are two height positions for the steering wheel. To adjust the height of the steering wheel, remove the hex bolt and hex lock nut on the steering shaft. Place the steering wheel in the position desired and secure with hex bolt and hex lock nut. Refer to figure 3.

### ➡ NOTE

When raising the height of the steering wheel, stretch the steering bellow to cover the steering shaft.

## DECK LEVELING ADJUSTMENT

If an uneven cut is obtained, the deck may be leveled as follows.

1. Remove the transmission cover:
  - a. Place the gear shift lever in the neutral position. Unscrew the gear shift knob.
  - b. Remove the two truss head screws which secure the transmission cover.
  - c. Lift the transmission cover. Unplug the safety wire from beneath the transmission cover, and remove cover.
2. Using a 1/2" wrench, loosen the jam nut. See figure 13.
3. With the unit on a hard, level surface, measure the distance from the bottom edge of the center of the left side of deck to the ground. Measure the same distance on the center of the right side of the deck (just behind the chute area on side discharge units). Or, place the blades in a straight line, and measure the distance from the outside edge of the blade tips to the ground.
4. Adjust the deck as follows: To lower the left side of the deck, tighten the adjusting screw. To raise the left side of the deck, back the adjusting screw off several turns. Remeasure the deck as described in step 3, and readjust if necessary. Tighten the jam nut to secure the adjusting screw when the deck is level.
5. Replace the transmission cover, following the instructions in step 1 in reverse order. Be certain to reconnect the safety wire.

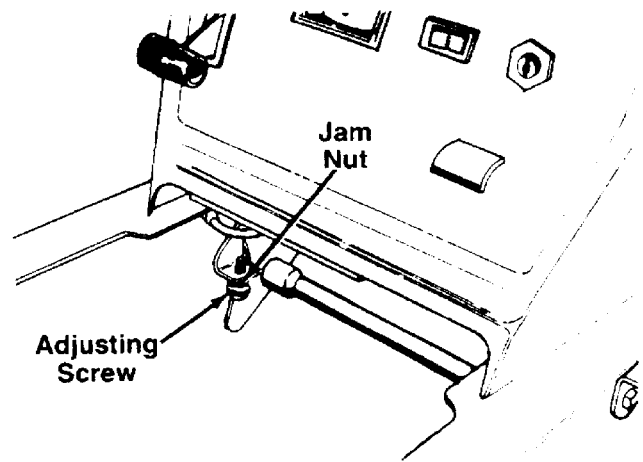

FIGURE 13.

## SPEED CONTROL ADJUSTMENT (See figure 14)

### ➡ NOTE

When operating the unit initially or after replacing the belts, there will be little difference between the highest two speeds until after the belts have gone through a break-in period and have seated themselves into the pulleys.

First, adjust the speed control lever by pushing the clutch-brake pedal forward until the stop on the speed control rod is against the running board rod. See figure 14. Have another person hold the pedal in this position as you make the following adjustment. Place the speed control lever in parking brake position. Remove the hairpin cotter and flat washer, and adjust the ferrule on the rod so it is against the back end of the slot. See figure 14. Replace the flat washer and hairpin cotter.

Next, adjust the speed control link as follows to obtain the correct neutral adjustment.

1. Start the engine.
2. Place the shift lever in NEUTRAL position.
3. Place the speed control lever in high speed position.
4. Release the clutch-brake pedal completely, then slowly depress the pedal all the way (to park position). Hold the pedal in this position.
5. Turn the engine off.
6. After engine stops completely, release the clutch-brake pedal.
7. Place speed control lever in second position.
8. Remove the cotter pin and flat washer which secures the speed control link to the variable speed torque bracket assembly.

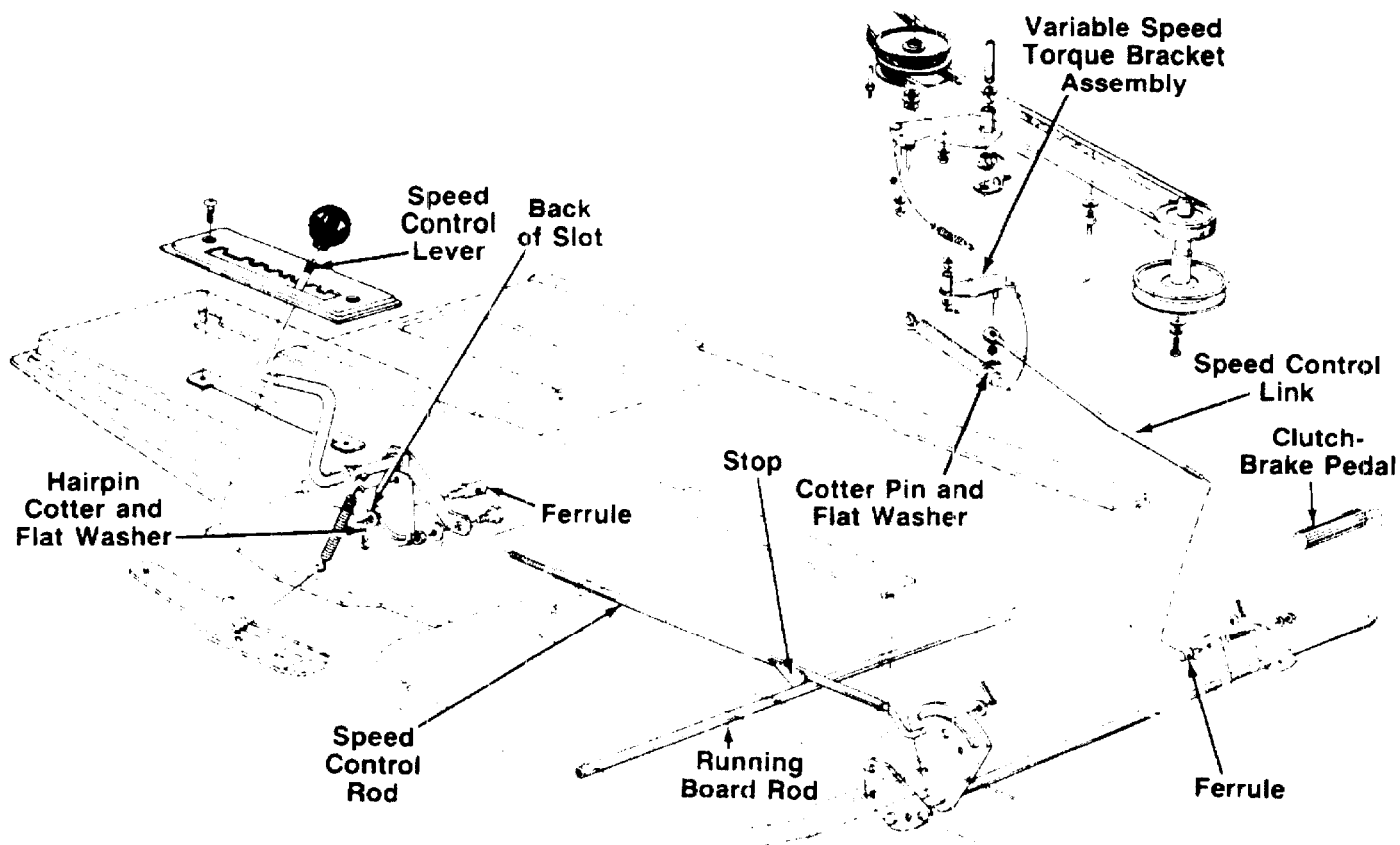

FIGURE 14.

9. Push the clutch-brake pedal backward by hand as far as it will go using light pressure. Hold it in this position as you thread the speed control link in or out of the ferrule until it lines up with the pin on the variable speed torque bracket assembly.
10. Secure speed control link to variable speed torque bracket assembly with flat washer and cotter pin.

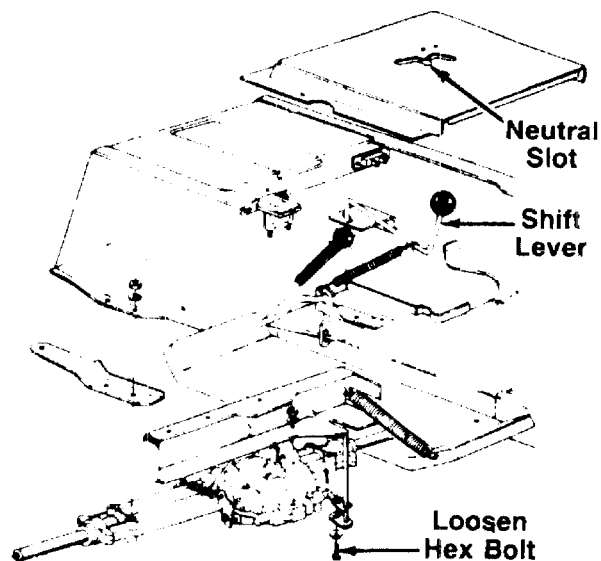

FIGURE 15.

#### NEUTRAL ADJUSTMENT

1. Place the transmission in neutral. (The unit will move freely when pushed forward and backward with the parking brake released).
2. Loosen the bolt which secures the shift lever assembly to the shift lever link. See figure 15.
3. Place the shift lever in the neutral slot. See figure 15.
4. Tighten the bolt to 13 foot pounds.

#### WHEEL ADJUSTMENT

The caster (forward slant of the king pin) and the camber (tilt of the wheels out at the top) require no adjustment. Automotive steering principles have been used to determine the caster and camber on the tractor. The front wheels should toe-in 1/8 inch.

To adjust the toe-in, follow these steps.

1. Remove the hex nut and lock washer, and drop the tie rod end from the wheel bracket. See figure 16.
2. Loosen the hex jam nut on tie rod.
3. Adjust the tie rod assembly for correct toe-in.

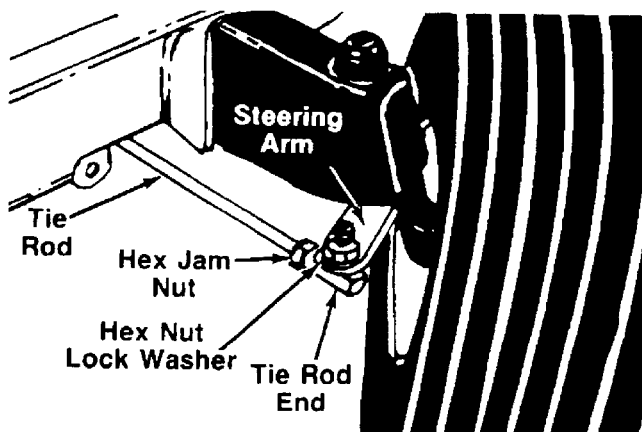

FIGURE 16.

Dimension "B" should be approximately 1/8" less than Dimension "A." See figure 17.

- A.) To increase Dimension "B," screw tie rod into tie rod end.
- B.) To decrease Dimension "B," unscrew tie rod from tie rod end.
- C.) Reassemble tie rod. Check dimensions. Readjust if necessary.

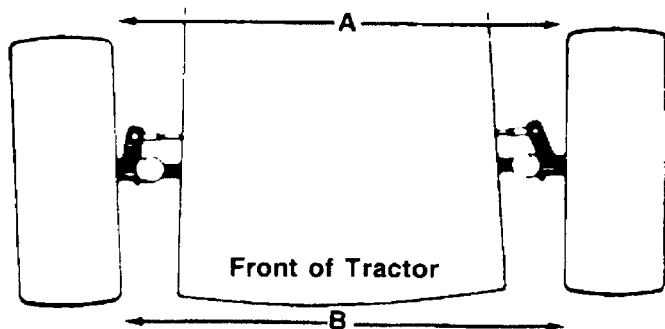

FIGURE 17. TOE-IN DIAGRAM

### CARBURETOR ADJUSTMENT



**WARNING**

If any adjustments are made to the engine while the engine is running (e.g. carburetor), disengage all clutches, and blades. Keep clear of all moving parts. Be careful of heated surfaces and muffler.

Minor carburetor adjustment may be required to compensate for differences in fuel, temperature, altitude and load. To adjust the carburetor, refer to the separate engine manual packed with your unit.

### NOTE

A dirty air cleaner will cause an engine to run rough. Be certain air cleaner is clean and attached to the carburetor before adjusting carburetor. Refer to the separate engine manual.

### BRAKE ADJUSTMENT (See figure 18)

The brake is located by the right rear wheel inside the frame. During normal operation of this machine, the brake is subject to wear and will require periodic examination and adjustment.



### CAUTION

Do not have the engine running when you adjust the brake.

To adjust the brake, remove the cotter pin. Adjust the castle nut so the brake starts to engage when the brake lever is 1/4" to 5/16" away from the axle housing.

### NOTE

Figure 18 is shown with the unit tipped up on rear wheels for clarity only.

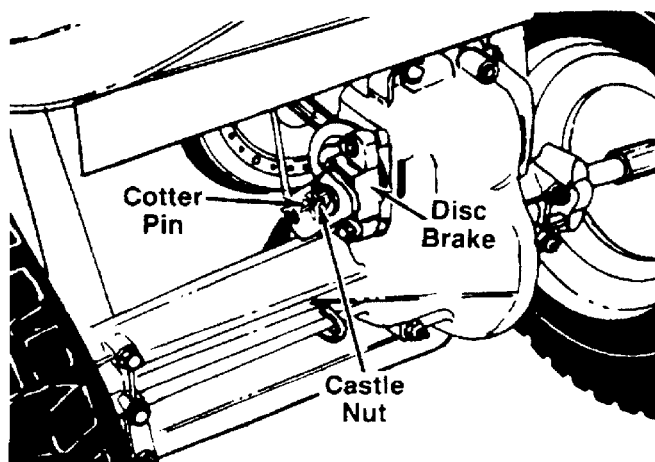

FIGURE 18.

### LUBRICATION



**WARNING**

Always stop engine and disconnect spark plug wire before cleaning, lubricating or doing any kind of work on lawn tractor.



## STEERING GEARS

Lubricate teeth of steering gears with automotive multi-purpose grease after every 25 hours of operation or once a season. See figure 19.

## STEERING SHAFT

Lubricate steering shaft at least once a season with light oil.

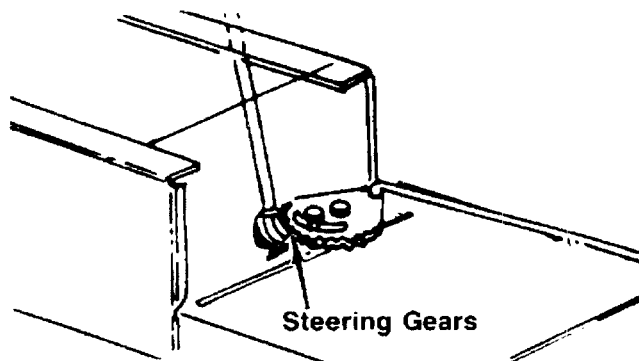

FIGURE 19.

## TRANSAXLE

The transaxle is lubricated and sealed at the factory and does not require checking. If disassembled for any reason, lubricate with 10 oz. of grease, part number 737-0148.

## FRONT WHEELS

The front wheels are provided with grease fittings. Lubricate at least once a season with automotive multi-purpose grease.

## PIVOT POINTS

Lubricate all pivot points with light oil at least once a season.

# MAINTENANCE



Disconnect the spark plug wire and ground against the engine before performing any repairs or maintenance.

## TROUBLE SHOOTING

Refer to page 21 of this manual for trouble shooting information.

## CRANKCASE OIL

Check the oil level in the crankcase before each use of the machine and after every five hours of operation. Oil level should be maintained as instructed in the separate engine manual.

After the first five hours of operating a new engine, drain the oil from the crankcase while engine is still hot and refill crankcase with new oil; thereafter change the oil every 25 hours of operation. Refer to the engine manual.

## AIR CLEANER

Under normal operating conditions, the air cleaner, located on top of the carburetor, must be serviced after every ten hours of use. Under extremely dusty operating conditions, the air cleaner must be serviced after every hour of operation. To service the air cleaner, refer to the separate engine manual packed with your unit.

## CLEANING ENGINE AND BLADE HOUSING

Any fuel or oil spilled on the machine should be wiped off promptly. Grass, leaves, and other dirt must not be left to accumulate around the cooling fins of the engine or on any part of the machine.

Clean the underside of the blade housing after each mowing.

## SPARK PLUGS

The spark plugs should be cleaned and the gaps reset once a season. Spark plug replacement is recommended at the start of each mowing season; check engine manual for correct plug type and gap specification.

## CUTTING BLADES

### A. Removal for Sharpening or Replacement



Be sure to disconnect and ground the spark plug wire and remove ignition key before working on the cutting blades to prevent accidental engine starting. Protect hands by using heavy gloves or a rag to grasp the cutting blades

Remove the large bolt and lock washer which holds the blade and adapter to the blade spindle. Remove the blade and adapter from the spindle.

If the blade or blade adapter needs replacing, remove the two small bolts, lock washers and nuts which hold the blade to the adapter.

### B. Sharpening

Remove the cutting blade by following the directions of the preceding section.

When sharpening the blade, follow the original angle of grind as a guide. It is **extremely important** that each cutting edge receives an equal amount of grinding to prevent an unbalanced blade. An unbalanced blade will cause excessive vibration when rotating at high speeds, may cause damage to the mower and could break, causing personal injury.

The blade can be tested for balance by balancing it on a round shaft screwdriver. Remove metal from the heavy side until it balances evenly.

**NOTE**

It is recommended that the blade always be removed from the adapter for the best test of balance.

**C. Reassembly**

Before reassembling the blade and the blade adapter to the unit, lubricate the spindle and the inner surface of the blade adapter with light oil. Lubricating the bolt holes, bolts and inner surface of the nuts with light oil is also recommended. A 4 oz. plastic bottle of light oil lubricant is available. Order part number 737-0170. Engine oil may also be used.

When replacing the blade, be sure to install the blade with the side of the blade marked "Bottom" (or with part number) facing the ground when the mower is in the operating position.

**Blade Mounting Torque**

3/8" Dia. Bolt 375 in. lb. min., 450 in. lb. max.

5/16" Dia. Bolt 150 in. lb. min., 250 in. lb. max.

To insure safe operation of your unit, ALL nuts and bolts must be checked periodically for correct tightness.

**FUEL FILTER**

Your unit is equipped with a replaceable in-line fuel filter. Replace filter whenever contamination or discoloration is noticed. Order replacement filter through your engine authorized service dealer.

**BELT REMOVAL AND REPLACEMENT**



**WARNING**

Disconnect the spark plug wire and ground it against the engine. Block the wheels of the unit.

**NOTE**

Figures 20 and 23 through 25 are shown with the unit tipped up for clarity. It is not necessary to tip the unit to remove the belts.

However, if tipping the unit is desired, remove the battery from the unit. To prevent gasoline leakage, drain the gasoline, or remove the fuel tank cap, place a thin piece of plastic over the neck of the fuel tank and screw on the cap. Be certain to remove the plastic when finished changing the belts. Block unit securely.

**Removing the Deck Belt**

1. Place the lift lever in the disengaged position.

2. Remove the three hex bolts (belt keepers) from the engine pulley belt guard. See figure 20.

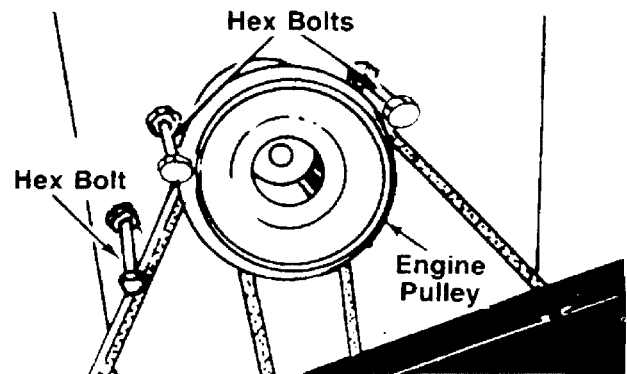

FIGURE 20.

**NOTE**

Make certain hex bolts are reassembled as shown in figure 20.

3. Unhook the deck belt from the engine pulley.
4. Place the lift lever in the engaged (all the way forward) position.
5. Disconnect the six deck links by removing the hair-pin cotters and flat washers.
6. Place the lift lever in the disengaged position.
7. Slide the deck from beneath the lawn tractor.
8. Remove the belt guards at each deck pulley by removing the hex bolts, lock washers and hex nuts. See figure 21.
9. Remove and replace the belt, following the instructions in reverse order.

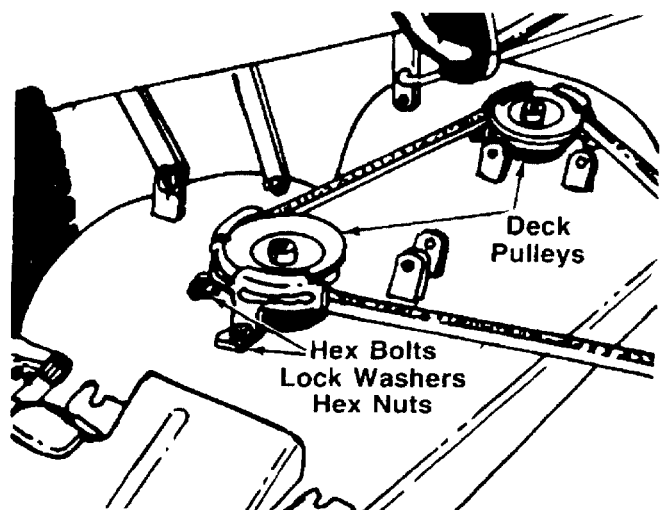

FIGURE 21.

**Rear Drive Belt**

1. Remove the two truss head screws which secure the transmission cover.

2. Lift the transmission cover. Unplug the safety wire from beneath the transmission cover. Remove transmission cover.
3. Push the idler pulley toward the right side of the unit. Lift the belt over the idler pulley. See figure 22.
4. Remove the belt from the variable speed pulley.
5. Remove the two bolts which hold the shift lever bracket to the frame on the left side of the unit. Swing the bracket toward the right so the belt can be removed from the transmission pulley. See figure 22.
6. Replace belt, and reassemble in reverse order.

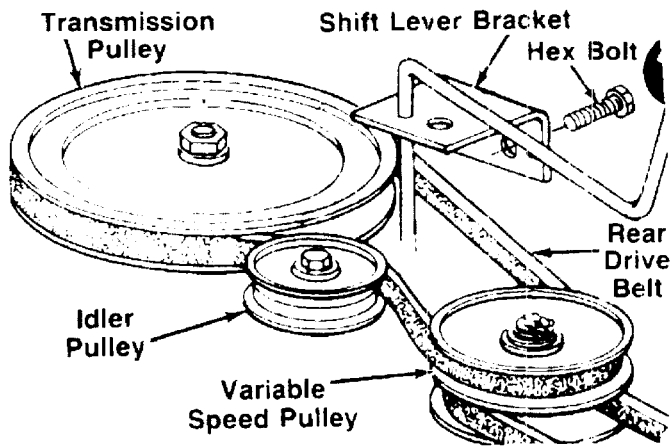

FIGURE 22.

#### Front Drive Belt

1. To remove the front drive belt, first remove the rear drive belt from the idler pulley and variable speed pulley.
2. Place the lift lever in the disengaged position.
3. Remove the hex bolts (belt keepers) from the engine pulley belt guard. Refer to figure 20.
4. Unhook the deck belt from the engine pulley.
5. Remove the two bolts, lock washers and nuts on each side of the frame which hold the engine pulley belt guard to the frame. See figure 23.

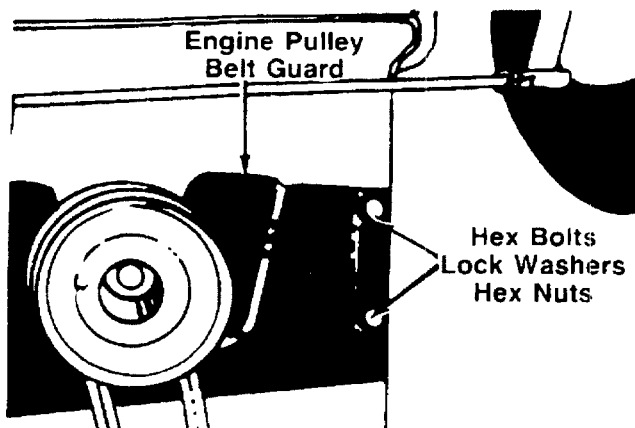

FIGURE 23.

5. Remove the engine pulley belt guard by slipping it back and to the right. See figure 24.

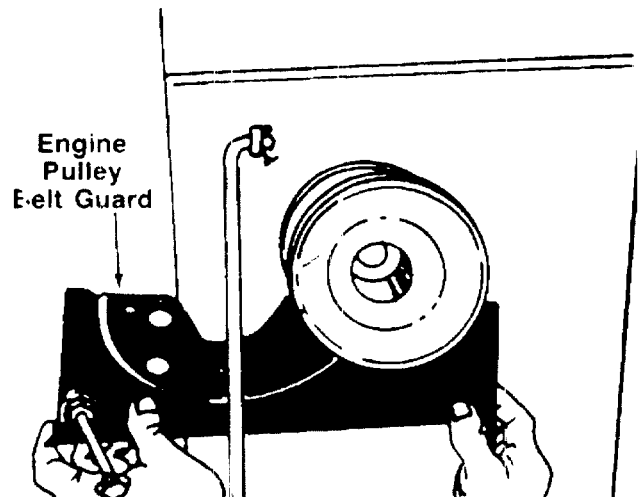

FIGURE 24.

7. Place the clutch-brake pedal in park position.
8. Push forward on the variable speed pulley, and lift the belt off the engine and remove the belt from the engine pulley.
9. Release the clutch-brake pedal. Using the pedal to move the variable speed pulley as necessary, lift the belt up and off the variable speed pulley.

#### NOTE

When reassembling, make certain belt is inside the pins. See figure 25.

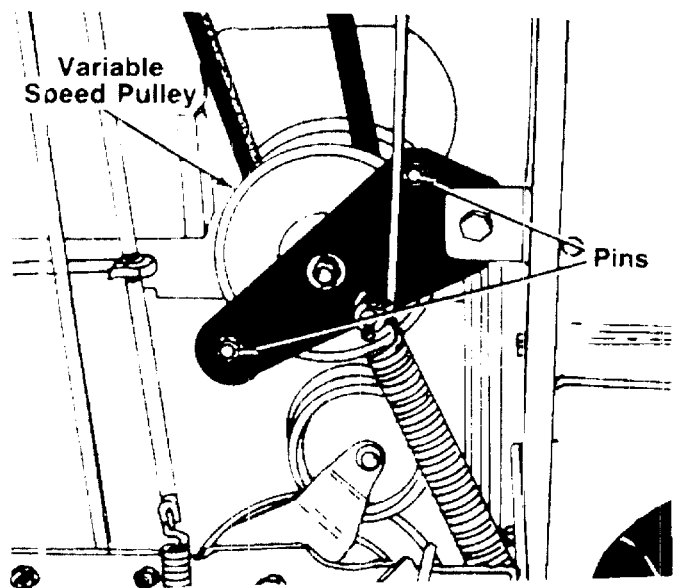

FIGURE 25.

10. Reassemble with a new belt, following instructions in reverse order.

## BATTERY REMOVAL OR INSTALLATION



When removing the battery, follow this order of disassembly to prevent the screwdriver from shorting against the frame.

1. Remove the Negative cable.
2. Remove the Positive cable.

To install a battery:

1. Attach the Positive cable.
2. Attach the Negative cable.

## JUMP STARTING

1. Attach the first jumper cable from the Positive terminal of the good battery to the Positive terminal of the dead battery.
2. Attach the second jumper cable from the Negative terminal of the good battery to the **FRAME OF THE UNIT WITH THE DEAD BATTERY.**



Failure to use this starting procedure could cause sparking, and the gas in either battery could explode.

## BATTERY MAINTENANCE

1. Check periodically (every two weeks or before and after charging) to be sure electrolyte level is above the lowest line on battery. Add only distilled water or a good quality drinking water. **NEVER** add additional acid or other chemicals to battery after initial activation.
2. The battery should be checked with a hydrometer after every 25 hours of operation. If the specific gravity is less than 1.225, remove battery and recharge.
3. Coat the terminals and exposed wiring with a thin coat of grease or petroleum jelly for longer service and protection against electrolyte corrosion.
4. The battery should be kept clean. Any deposits of acid should be neutralized with soda and water. Be careful not to get this solution in the cells.

## BATTERY STORAGE

1. Charge battery using normal methods. **NEVER** store discharged battery as it will not recover.
2. When storing battery for extended periods, disconnect battery cables. Removing battery from unit is recommended.
3. Store in cold, dry place.

4. Recharge battery whenever the specific gravity is less than 1.225, before returning to service, or every two months, whichever occurs first.

## COMMON CAUSES FOR BATTERY FAILURE ARE:

1. Overcharging
2. Undercharging
3. Lack of water
4. Loose hold downs and/or corroded connections
5. Excessive loads
6. Battery electrolyte substitutes
7. Freezing of electrolyte



THESE FAILURES DO NOT CONSTITUTE WARRANTY.

## INSTALLATION OF TIRE TO RIM



The following procedure must be followed when removing or installing a tire to the rim.

1. Be sure rim is clean and rust free.
2. Lubricate both the tire and rim generously.
3. Never inflate to over 30 p.s.i. to seat beads. Excessive inflation pressure when seating beads may cause tire/rim assembly to burst with force sufficient to cause serious injury.

## OFF-SEASON STORAGE

If the machine is to be inoperative for a period longer than 30 days, prepare for storage as follows.

1. Clean the engine and the entire unit thoroughly.
2. Lubricate all lubrication points. Wipe the entire machine with an oiled rag to protect the surfaces.
3. Refer to the engine manual for correct engine storage instructions. The engine must be completely drained of fuel to prevent gum deposits from forming on essential carburetor parts, fuel lines and fuel tanks.
4. Refer to battery storage instructions in previous column.
5. Store unit in a clean, dry area.



When storing any type of power equipment in an unventilated or metal storage shed, care should be taken to rustproof the equipment. Using a light oil or silicone, coat the equipment, especially any chains, springs, bearings and cables.

# TROUBLE SHOOTING CHART FOR ELECTRIC START MODELS

TROUBLE	LOOK FOR	REMEDY
Engine will not crank	Battery is installed incorrectly	The battery must be installed with the negative terminal, identified at the terminal post by (Neg. N or -), grounded. The positive terminal (Pos. P or +) attaches to the large cable from the solenoid. The small red wire from the fuse holder or circuit breaker is also attached to the positive terminal.
	Blown fuse or circuit breaker	Replace fuse with 7 amp fuse 1/4 x 1 1/2" lg. Circuit breaker will reset itself when it cools off. Fuses or circuit breakers seldom open or fail without a reason. The problem must be corrected. Check for loose connections in the fuse holder. Replace fuse holder if necessary. A dead short may be in the cranking or charging circuit where the insulation may have rubbed through and exposed the bare wire. Replace the wire or repair with electrician's tape if the wire strands have not been damaged. Note: Look for a wire pinched between body panels, turned by the exhaust pipe or muffler or rubbed against a moving part.
	Battery is dead or weak	<p>Use a hydrometer to check the condition of the battery. The Specific Gravity (s.g.) should be 1.265 at 80° F. (1.215 s.g. minimum needed for cranking engine). The reason for the battery failing must be determined: (1) Defective battery. Battery will not accept or hold a full charge. (2) Short circuit. Check for grounded wire. (3) Charging system not working.</p> <p>The charging system is an alternator located under the flywheel. It is unregulated and rated 3 amp. at 3600 r.p.m. A diode rectifier is located in the output lead just before the wire harness plug on the engine side.</p> <div style="text-align: center;"> </div> <p>The diode changes A.C. to D.C. to charge the battery. A bad diode can either fail to charge the battery or discharge the battery if the alternator is shorted as well as the diode. To test: (1) Disconnect charger lead from the battery (small red wire). (2) Connect 12 V small test lamp between the 3 amp. D.C. charge lead and the positive terminal of the battery. (3) With the engine off, the lamp should not light. If it does, the diode and possibly the alternator should be replaced. (4) Start the engine. The lamp should light. If it does not, the alternator (stator) or lead wire is bad and should be replaced.</p>
Mechanical failure (Wires and switches)	The interlock system includes two mechanical activated switches which are wired in series in the circuit used to energize the starter solenoid. While testing the interlock system, you will make the mower temporarily unsafe by permitting the engine to be started with the blade and clutch engaged. <b>WARNING:</b> While testing, disengage the clutch, shut off the blade control, set the parking brake and place the gear shift lever in neutral. Attach a wire (minimum 18 gauge) to the positive terminal of the battery and touch the other end to the small terminal on the solenoid. <b>If the engine does not crank:</b> (1) There is a loose connection or poor ground. (2) The solenoid may be bad. The solenoid can be checked by using a heavy wire (#8 gauge minimum) and jumping between the two large terminals. If the engine cranks, the solenoid is bad. (3) If the engine does not crank when you jump the solenoid, have the starter motor tested by an authorized engine dealer. If the engine does crank, the problem is with one of the safety switches, light on switch or the wire between the fuse holder (or circuit breaker) and the small terminal on the solenoid. Note: Look for a poor connection at the switches or a defective switch. Replace if necessary.	
Engine cranks but will not start	Throttle or choke not in starting position	Check owner's guide for correct position for throttle control and choke for starting.
	No spark to spark plug	<p>Spark plug lead disconnected. Connect lead. Hold spark plug lead away from engine block about 1/8". Crank engine. There should be a spark. If not, have engine repaired at authorized engine service dealer.</p> <p>Faulty spark plug. To test, remove spark plug. Attach spark plug lead to spark plug. Ground the spark plug body against the engine block. Crank the engine. The spark plug should fire at the electrode. Replace if it does not.</p>

## TROUBLE SHOOTING CHART FOR ELECTRIC START MODELS

TROUBLE	LOOK FOR	REMEDY
	No fuel to the carburetor	Gasoline tank empty. Fill. Fuel line or in-line fuel filter plugged. Remove and clean fuel line. Replace filter if necessary.
	Air filter dirty	If the air cleaner is dirty, the engine may not start. Clean or replace as recommended by the engine manufacturer.
Engine smokes	Engine loses crankcase vacuum	Dipstick not seated or broken. Replace defective part. Engine breather defective. Replace.
Excessive vibration	Bent or damaged blade spindle	<b>Stop engine immediately.</b> Check all pulleys, blade adapters, keys and bolts for tightness and damage. Tighten or replace any damaged parts.
	Bent blade	<b>Stop engine immediately.</b> Replace damaged blade. Only use original equipment blades.
Mower will not discharge grass or leaves uncut strips	Engine speed low Transmission selection Blades short or dull	Throttle must be set between 3/4 and full throttle. Use lower transmission speed. The slower your ground speed, the better the quality of cut. Sharpen or replace blades (uncut strip problem only).

# TMO-33934A

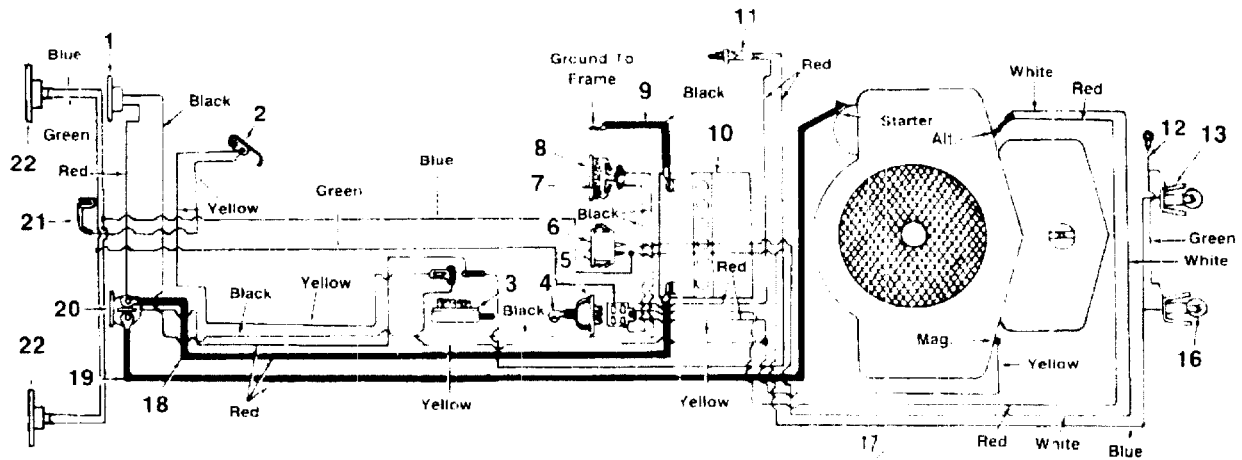

## PARTS LIST FOR ELECTRICAL SYSTEM

REF. NO.	PART NO.	DESCRIPTION	NEW REF. PART NO.	PART NO.	DESCRIPTION	NEW PART
1	725-0459	Circuit Breaker	11	725-0577	Safety Switch	N
2	725-0759	Spring Switch	12	725-0916	Ground Wire	
3	725-0819	Safety Switch Opst.	13	725-1058	Socket	
4	725-0201	Ignition Key	16	725-0963	Lamp	
5	725-0267	Ignition Switch	17	725-1314	Wire Harness	
6	725-0634	Headlight Switch	18	725-1080	Electric Wire 27 0" Lg.	
7	722-0135	Foam Strip	19	725-0562	Electric Wire 32 5" Lg.	
8	725-0925	Ammeter	20	725-0771	Solenoid	
9	725-0994	Ground Wire 14.0" Lg	21	725-1303	Spring Switch	
10	725-0453	12 Volt Battery	22	725-1128	Taillight	

Part No.	Description
788-0621	Brilliant Fire Mist Spray Paint
788-0637	Black Spray Paint
777-5268	Steering Cap Label
777-7528	F-N-R Shift Label
777-6827	Montgomery Ward Logo—Grille
777-6891	Label—7 Speed
777-7002	Montgomery Ward Logo— Side of Hood
777-7059	Labels—Frame Side
777-7094	Labels—Hood Stripe
777-7100	Plastic Hood Side Stripe
777-7289	Label—Dash Panel
770-6480C	Operating Manual

# TMO-33934A

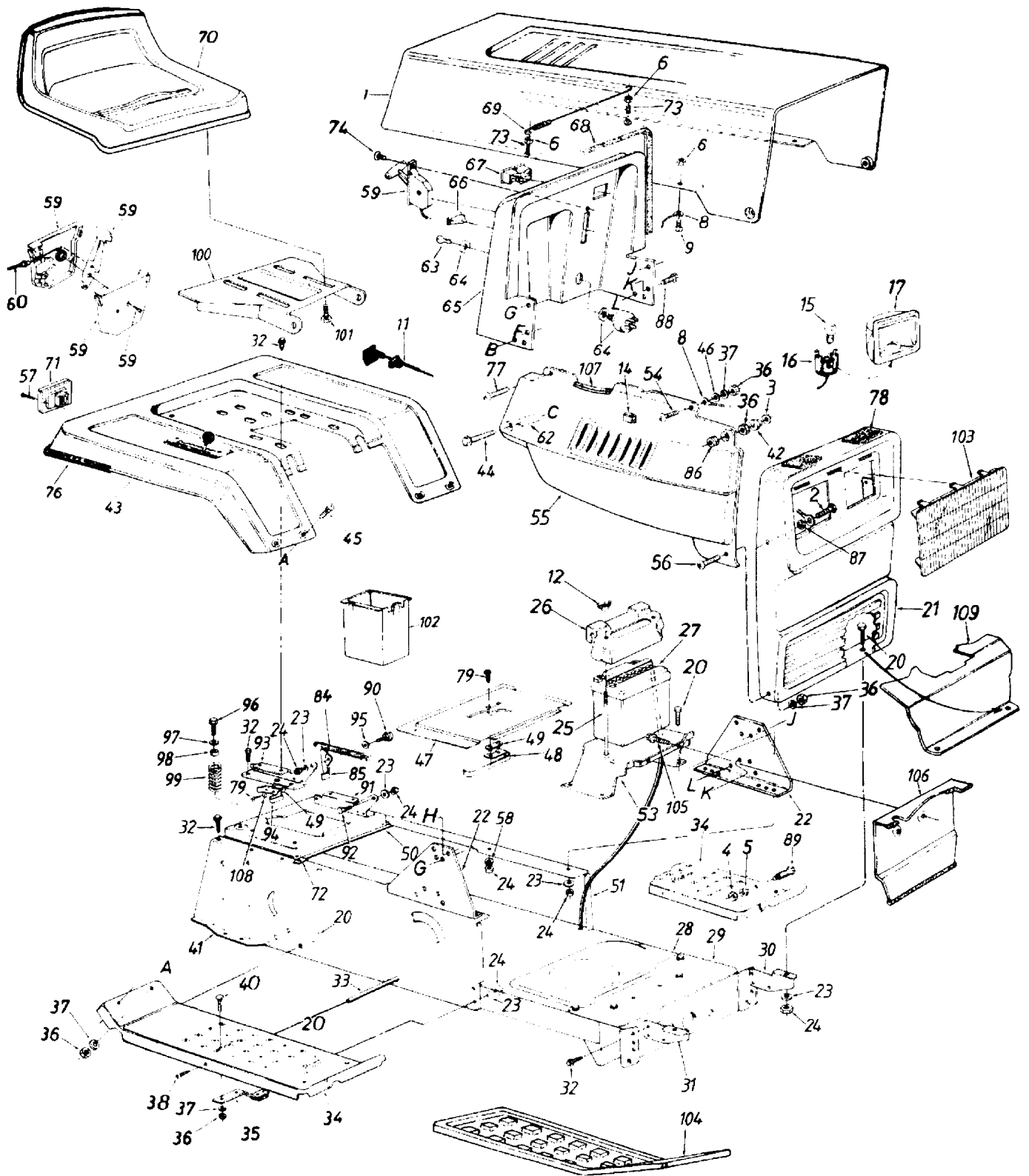



# TMO-33934A

## 14 H.P. 38" LAWN TRACTOR PARTS LIST FOR MODEL TMO-33934A

REF. NO.	PART NO.	DESCRIPTION	NEW PART	REF. NO.	PART NO.	DESCRIPTION	NEW PART
1	16787CC621	Hood		57	710-0936	Truss Hd. AB-Tap Scr. #6 x .62" Lg.	
2	710-0206	Hex Bolt 1/4-20 x .86" Lg.		58	736-0607	Ext. L-Wash. 5/16" I.D.	
3	736-0413	Washer .39" I.D. x .62" O.D.		59	831-0823	Throttle Control Box Ass'y.	
4	736-0169	L-Wash. 3/8" I.D. *		60	746-0634	Throttle Control Wire 35"	
5	712-0798	Hex Nut 3/8-16 Thd. *		62	750-0583	Spacer 1.32" Lg.	
6	712-0272	Hex Sems Nut #10-24 Thd. *		63	725-0201	Ignition Key	
8	727-0290	Hood Stop		64	725-0267	Ignition Switch	
9	710-0473	Truss Hd. Scr. #10-24 x 1/2" *		65	17295	Dash Panel	
11	746-0613	Choke Control 46.0" Lg.		66	725-0634	Light Switch	
12	712-0113	Wing Nut 1/4-20 Thd —Plastic		67	725-0925	Ammeter	
14	726-0152	Clamp		68	731-0511	Trim Strip—27"	
15	725-0963	Lamp		69	732-0462	Hood Spring	
16	725-1058	Twist Lock—Lamp Socket		70	757-0338	Seat Ass'y.	N
17	731-0705	Headlight Housing		71	725-1128	Taillight	
20	710-0118	Hex Bolt 5/16-18 x .75" Lg. *		72	726-0139	Speed Nut #10Z	
21	16456	Grille	N	73	710-0749	Hex Scr. #10-24 x 1.0" Lg.	
22	17300	Dash Support Bracket		74	710-0779	Truss Mach. AB-Tap Scr. #10 x .5" Lg.	
23	736-0119	L-Wash. 5/16" I.D. *		76	731-0511	Trim Strip—81"	
24	712-0267	Hex Nut 5/16-18 Thd. *		77	710-0642	Hex Wash. Hd. Tap Scr. 1/4 x .75" Lg.	
25	711-0222	Battery Hold Down Rod		78	722-0157	Foam Strip 3/8 x 1-1/8 x 1 1/2" Lg. (4-Rec'd.)	
26	731-0707	Battery Cover		79	710-0227	Hex Wash. Hd. AB-Tap Scr. #8 x .50" Lg.	
27	725-0453	12 Volt Battery		84	732-0581	Ext. Spring 5.31" Lg.	N
28	15930	Lower Frame		85	17239	Seat Lift Brkt.	N
29	14619	Front Pivot Brk't.		86	712-0264	Acorn Nut 1/4-20 Thd.	
30	15821	Grille Mount Brk't.—L.H.		87	736-0222	External L-Wash. 1/4" Thd.	
31	15822	Grille Mount Brk't.—R.H.		88	710-0624	Hex Bolt 5/16-24 x 1.5" Lg.	
32	710-0726	Hex Wash. Hd. AB-Tap Scr. 5/16 x .75" Lg.		89	738-0145	Shoulder Bolt	
33	738-0526	Running Board Rod		90	738-0296	Shld. Bolt .437" Dia. x .268"	
34	14604	Running Board (R.H. & L.H.)		91	17243	Seat Pivot Brkt. Support—L.H.	N
35	761-0168	Blade Brake Ass'y.		92	738-0155	Shld. Bolt .437" Dia. x .162"	
36	712-0287	Hex Nut 1/4-20 Thd. *		93	17244	Seat Pivot Brkt. Support—R.H.	N
37	736-0329	L-Wash. 1/4" I.D. *		94	725-1303	Spring Switch	N
38	710-0323	Truss Mach. Scr. 5/16-18 x .75" Lg. *		95	736-0141	Spr.-Wash. .445" I.D.	
40	710-0134	Carr. Bolt 1/4-20 x .62"		96	710-0602	Hex Wash. Hd. Tap Scr. 5/16-18 x 1" Lg.	
41	14602	R.H. Side Frame		97	736-0159	Fl-Wash. .344" I.D.	
42	738-0759	Shld. Spacer	N	98	722-0160	Bushing	N
43	17231CC621	Rear Fender		99	732-0588	Compression Spring	N
44	710-1026	Hex Tap Scr. 1/4-20 x 1.75" Lg.	N	100	15607	Seat Pivot Bracket	
45	710-0167	Carriage Bolt 1/4-20 x .50" Lg. *		101	710-0623	Hex Tap Scr. 3/8-16 x .75"	
46	736-0173	Fl-Wash. .281" I.D. x .73"		102	731-0873	Utility Box	N
47	17286	Transmission Panel	N	103	731-0967	Headlight Bezel	N
48	725-0759	Reverse Safety Switch		104	731-0909	Foot Pad—L.H.	N
49	726-0222	Insulator Nut Plate			731-0910	Foot Pad—R.H.	N
50	17226	Hitch Plate	N	105	710-0599	Hex Tap Scr. 1/4-20 x 5" Lg.	
51	14603	L.H. Side Frame		106	16804	Baffle	N
53	12747	Battery Bracket		107	731-0511	Trim Strip 6" Lg.	
54	710-0255	Truss Hd. Scr. 1/4-20 x .75" Lg. *		108	736-0426	Fiber Washer	
55	16824	Side Cover—R.H.	N	109	16831	Heat Shield	N
	16825	Side Cover—L.H. (Not Shown)	N				
56	710-0286	Truss Mach. Scr. 1/4-20 x .50" Lg. *					

NOTE: Specifications subject to change without notice or obligation.

\*Common Hardware—May be purchased locally. Important: **Do not** order by reference number (Ref. No.).

# TMO-33934A

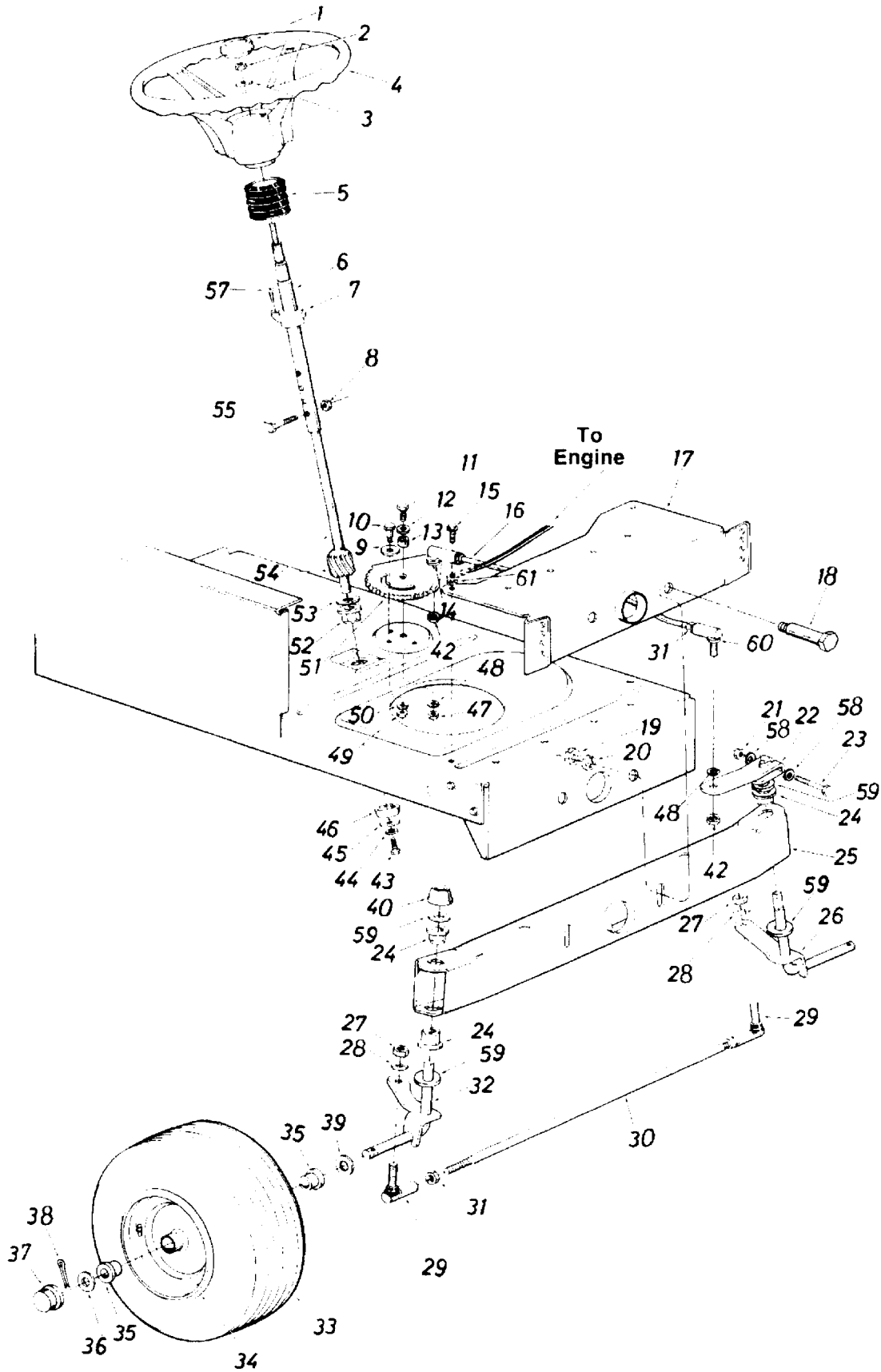

# TMO-33934A

## 14 H.P. 38" LAWN TRACTOR PARTS LIST FOR MODEL TMO-33934A

REF. NO.	PART NO.	DESCRIPTION	NEW PART	REF. NO.	PART NO.	DESCRIPTION	NEW PART
1	731-0220	Steering Wheel Cap		32	14650	Front Axle Ass'y.—R.H.	
2	712-0237	Hex L-Nut 5/16-24 Thd.		33	734-0863	Wheel Ass'y Comp.	
3	736-0242	Belleville Wash. .345" I.D.			734-0864	Tire Only	
4	731-0806	Steering Wheel		34	734-0997	Front Wheel Rim Only	
5	731-0559	Steering Bellow			734-0255	Air Valve	
6	16512	Steering Column Ass'y.			737-0146	Grease Fitting	
7	741-0356	Flange Bearing .890" I.D. x 1.36" O.D.		35	741-0487	Bearing	
8	712-0324	Hex L-Nut 1/4-20 Thd.		36	736-0285	FI-Wash. .635" I.D. x 1.59" O.D.	
9	736-0319	FI-Wash. .438" I.D. x 1.37"		37	731-0484	Front Wheel Hub Cap	
10	738-0141	Shoulder Bolt .437" Dia. x .35" Lg. 5/16-18 Thd.		38	714-0470	Cotter Pin 1/8" Dia. x 1.25" Lg.*	
11	710-0152	Hex Bolt 3/8-24 x 1.0" Lg. (Grade 5)		39	736-0187	FI-Wash. .640" I.D. x .24" O.D.	
12	736-0219	Bell-Wash. .40" I.D. x 1.13"		40	726-0214	Push Cap 5/8" Dia. Rod	
13	750-0535	Spacer .380" I.D. x .625" O.D. x .227"		42	712-0711	Hex Jam Nut 3/8-24 Thd.*	
14	736-0169	L-Wash. 3/8" I.D.*		43	710-0538	Hex L-Bolt 5/16-18 x .62"*	
15	710-0726	Hex Wash. Hd. Self-Tap Scr		44	736-0119	L-Wash. 5/16" I.D.*	
16	711-0788	Steering Drag Link		45	736-0343	FI-Wash. .33" I.D. x 1.25" O.D.	
17	14619	Front Pivot Brkt.		46	750-0532	Spacer (Plastic)	
18	738-0527	Shoulder Bolt .498" Dia. x 2.04" Lg. 3/8-16 Thd.		47	712-0241	Hex Nut 3/8-24 Thd.*	
19	712-0798	Hex Nut 3/8-16 Thd.*		48	736-0169	L-Wash. 3/8" I.D.*	
20	736-0169	L-Wash. 3/8" I.D.*		49	712-0267	Hex Nut 5/16-18 Thd.*	
21	712-0237	Hex Cent L-Nut 5/16-24 Thd.		50	736-0119	L-Wash. 5/16" I.D.*	
22	16481	Steering Arm Front Axle		51	717-0622	Steering Gear Segment	
23	710-0772	Hex Bolt 5/16-24 x 2.00" Lg. (Grade 5)		52	741-0225	Hex Flg. Brg. .634 I.D.	
24	741-0225	Hex Flg. Brg. .634" I.D.		53	736-0187	FI-Wash. (Hardened)	
25	14608	Pivot Bar Ass'y.		54	738-0522	Steering Shaft Lower	
26	16479	Front Axle Ass'y.—L.H.		55	710-0958	Hex Bolt 1/4-20 x 1.31" Lg.	
27	712-0241	Hex Nut 3/8-24 Thd.*		57	710-0837	Oval Hd. Cr.—Sunk Scr. #10 x 5/8" Lg.	
28	736-0169	L-Wash. 3/8" I.D.*		58	736-0271	Wave Wash. .32" I.D. x .62"	
29	723-3018	Ball Joint 3/8-24 Thd.		59	736-0187	FI-Wash. (Hardened)	
30	711-0613	Tie Rod		60	723-3018	Drag Link Ball Joint 3/8-24 Thd.	
31	712-0711	Hex Jam Nut 3/8-24 Thd *		61	736-0607	Ext. L-Wash 5/16" I.D.	

\*Common Hardware—May be purchased locally.  
Important: **Do not** order by reference number (Ref. No.).

# TMO-33934A

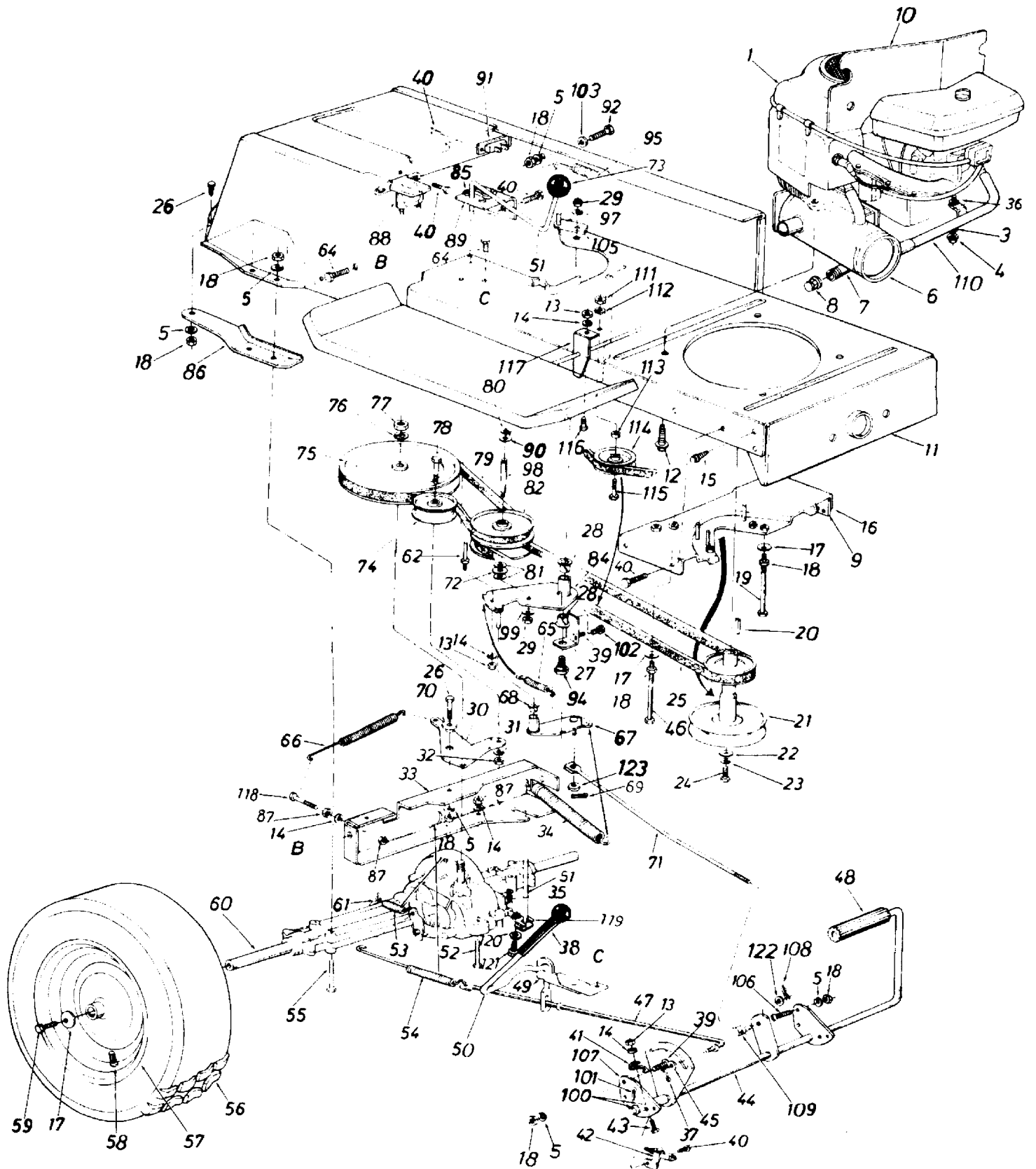

# TMO-33934A

## 14 H.P. 38" LAWN TRACTOR PARTS LIST FOR MODEL TMO-33934A

REF. NO.	PART NO.	DESCRIPTION	NEW PART	REF. NO.	PART NO.	DESCRIPTION	NEW PART
1	14 H.P.	Engine—B&S 400707-1209-01		56	734-0817	Wheel Ass'y. Comp.	
3	736-0170	Special L-Wash 5/16" I.D.			734-0448	Tire Only	
4	712-0267	Hex Nut 5/16-18 Thd.*		57	734-0603	Wheel Rim Only	
5	736-0119	L-Wash. 5/16" I.D.*		58	734-0255	Air Valve (Service Only)	
6	751-0444	Exhaust Muffler		59	710-0627	Hex Bolt 5/16-24 x .75" Lg.*	
7	737-0164	Pipe Nipple		60	717-1050	Transaxle Complete—R.H.	
8	737-0143	Cap Oil Drain		61	732-0454	Brake Return Spring Anchor	
9	16371	Brake Cable Brkt.		62	711-0768	Belt Guard Pin 1/4-20 Thd.	
10	16224	Heat Shield		64	710-0604	Hex Wash. TT-Tap Scr. 5/16 x 62" Lg	
11	15930	Lower Frame Ass'y.		65	732-0568	Ext. Spring	
12	710-0502	Hex Wash. Hd. TT-Tap Scr. 3/8-16 x 1.25" Lg		66	732-0384	Ext. Spring 62" O.D. x 6.12"	
13	712-0287	Hex Nut 1/4-20 Thd.*		67	16554	Variable Speed Torque Brkt. Ass'y.	
14	736-0329	L-Wash. 1/4" I.D.*		68	741-0419	Flanged Bearing	
15	710-0726	Hex Wash. Hd. AB-Tap Scr. 5/16" x .75" Lg		69	714-0507	Cotter Pin 3/32" Dia.*	
16	16219	Belt Guard Brkt. Ass'y.		70	748-0234	Shoulder Spacer .500" Dia. x .27" Lg	
17	736-0242	Bell-Wash. .345" I.D. x .88"		71	747-0530	Speed Control Link	
18	712-0267	Hex Nut 5/16-18 Thd.*		72	741-0405	Truss Bearing .56" Dia. x 1.25"	
19	710-0190	Hex Bolt 5/16-18 x 4.00**		73	720-0165	Ball Knob	
20	714-0114	Sq. Key 1/4" x 1/4" x 2.00"		74	756-0437	FI-Idler Pulley 3.25" x .75"	
21	756-0424	Engine Pulley		75	756-0374	1/2" V-Pulley 8.0" O.D. x .501" I.D.	
22	736-0322	FI-Wash. 7/16" I.D. x 1.25"		76	736-0921	L-Wash. 1/2" I.D.*	
23	736-0171	L-Wash. 7/16" I.D.*		77	712-0922	Hex Jam Nut 1/2-20 Thd.*	
24	710-0757	Hex Bolt 7/16-20 x 1.50" Lg.		78	710-0539	Hex Bolt 3/8-24 x .75" Lg.*	
25	754-0280	Variable-Speed Belt		79	754-0281	Variable-Speed Belt	
26	710-0118	Hex Bolt 5/16-18 x .75" Lg.*		80	716-0114	Snap Ring .56" Dia.	
27	16553	Bearing Shaft Bracket Ass'y		81	736-0355	FI-Wash.	
28	741-0295	Flanged Nyliner Brg 5/8" I.D. x .88" Lg.		82	717-0800	Variable Speed Pulley Ass'y. 5" O.D	
29	712-0241	Hex Nut 3/8-24 Thd.*		84	16354	Variable Speed Brkt. Ass'y.	
30	15891	Idler Bracket		85	732-0525	Comp. Spring Clip	
31	736-0169	L-Wash. 3/8" I.D.*		86	14770	Transaxle Support Brkt.— R.H.	
32	712-0241	Hex Nut 3/8-24 Thd.*			14769	Transaxle Support Brkt.— L.H. (Not Shown)	
33	15945	Transaxle Support Brkt.		87	712-0138	Hex Nut 1/4-28 Thd.	
34	732-0459	Ext. Spring .94" O.D. x 6.7"		88	725-0771	Solenoid	
35	714-0149	Inter. Cotter Pin		89	16429	Shift Lever Bracket	
36	736-0204	FI-Wash. .34" I.D. x .62" O.D. x .033"		90	736-0414	Teflon Washer	
37	714-0507	Cotter Pin 3/32" Dia. x .75"		91	725-0459	Circuit Breaker	
38	720-0143	Grip—Black		92	710-0959	Hex Bolt 5/16-18 x 1.50" Lg.	
39	710-0323	Truss Mach. Scr. 5/16-18 x .75" Lg.		94	738-0755	Shld. Bolt 3/8-24 x 3.12" Lg.	
40	710-0599	Hex Wash. Hd. Self-Tap Scr. 1/4-20 x .50" Lg.		95	732-0307	Ext. Spring .99" O.D. x 11.0"	
41	732-0582	Switch Actuator	N	96	710-0180	Hex Bolt 3/8-24 x .75" Lg.*	
42	725-0577	Safety Switch		97	736-0105	Bell-Wash. .38" I.D. x .88"	
43	710-0597	Hex Bolt 1/4-20 x 1.0" Lg.*		98	738-0569	Shaft .56" Dia. x 3.875" Lg.	
44	16235	Clutch & Brake Pedal Ass'y		99	736-0331	Bell-Wash. .39" I.D. x 1.12"	
45	736-0117	FI-Wash.		100	736-0256	FI-Wash.	
46	710-0402	Hex Bolt 5/16-18 x 4.5**		101	714-0507	Cotter Pin 3/32" Dia. x .75"	
47	747-0519	Brake Rod 20.9" Lg.		102	710-0604	Hex Wash. Hd. Scr. 5/16-18 x .62" Lg.	
48	735-0196	Foot Pad		103	736-0231	FI-Wash. .34" I.D. x 1.12"	
49	15889	Brake Lever Bracket		105	16067	Belt Guard	
50	15888	Hill Holder Brake Handle		106	710-0118	Hex Bolt 5/16-18 x .75" Lg.*	
51	16430	Shift Lever Ass'y		107	15835	Pedal Bracket	
52	710-0559	Hex Bolt 1/4-28 x 1.75" Lg.*		108	714-0507	Cotter Pin 3/32 x .75"	
53	732-0264	Ext. Spring x 2.5" Lg.					
54	732-0413	Ext. Spring x 7.08" Lg.					
55	710-0176	Hex Bolt 5/16-18 x 2.75**					

# TMO-33934A

## 14 H.P. 38" LAWN TRACTOR PARTS LIST FOR MODEL TMO-33934A (CONTINUED)

REF. NO.	PART NO.	DESCRIPTION	NEW PART	REF. NO.	PART NO.	DESCRIPTION	NEW PART
109	711-0198	Ferrule		117	16181	Spring Hanger Bracket	
110	751-0446	Inlet Tube Ass'y.		118	710-0428	Hex Bolt 1/4-28 x 1.25" Lg.*	
111	712-0798	Hex Nut 3/8"-16 Thd.*		119	16437	Shift Lever Link Ass'y.	
112	736-0169	L-Wash. 3/8" I.D.*		120	736-0270	Bell-Wash. .265" I.D. x .75"	
113	736-0280	FI-Wash. .390" I.D. x 1.12"		121	710-0195	Hex Bolt 1/4-28 x .62" Lg.	
114	756-0217	FI-Idler w/Flanges 2.750		122	736-0140	FI-Wash. .385" I.D. x .62"	
115	710-0427	Hex Bolt 3/8-16 x 2.00" Lg.*		123	736-0275	FI-Wash. .34" I.D. x .68" O.D.	
116	710-0258	Hex Bolt 1/4-20 x .62" Lg.*					

# TMO-33934A

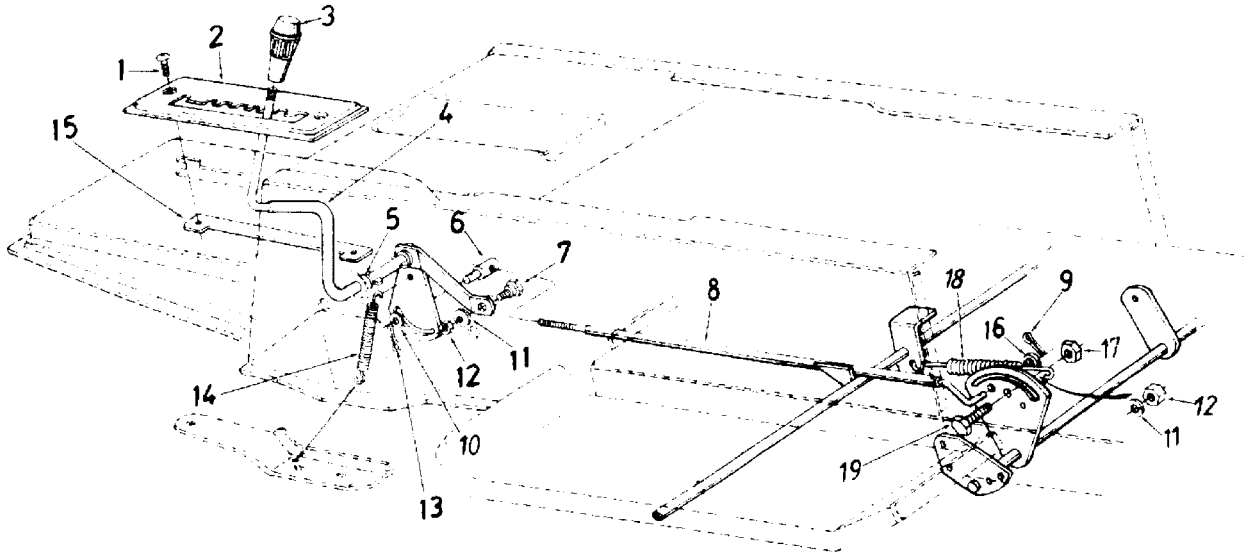

## 14 H.P. 38" LAWN TRACTOR PARTS LIST FOR MODEL TMO-33934A

REF. NO.	PART NO.	DESCRIPTION	NEW PART	REF. NO.	PART NO.	DESCRIPTION	NEW PART
1	710-0924	Truss Mach. Scr. 1/4-20 x .75" Lg.		10	736-0140	FI-Wash. .385" I.D. x .62"	
2	16194	Speed Selector Plate 7-Speed		11	736-0119	L-Wash. 5/16" I.D.*	
3	720-0218	Shift Knob	N	12	712-0267	Hex Nut 5/16-18 Thd.*	
4	16192	Speed Selector Cam Ass'y.		13	714-0507	Cotter Pin 3/32 Dia. x .75" *	
5	736-0192	Flat Washer .53" I.D. x .93"		14	732-0303	Spring	
6	711-0198	Ferrule 3/8-24 x .37" Dia.		15	16196	Clamping Plate	
7	738-0155	Shoulder Bolt .435" Dia. x .160		16	736-0226	FI-Wash. .47" I.D. x .88" O.D.	
8	16355	Speed Control Rod Ass'y.		17	712-0158	Hex L-Nut 5/16-18 Thd.	
9	714-0507	Cotter Pin 3/32" Dia. x .75" *		18	732-0470	Ext. Spring 4.75" Lg.	
				19	710-0376	Hex Cap Bolt 5/16-18 x 1" Lg. (Grade 5)	

# TMO-33934A

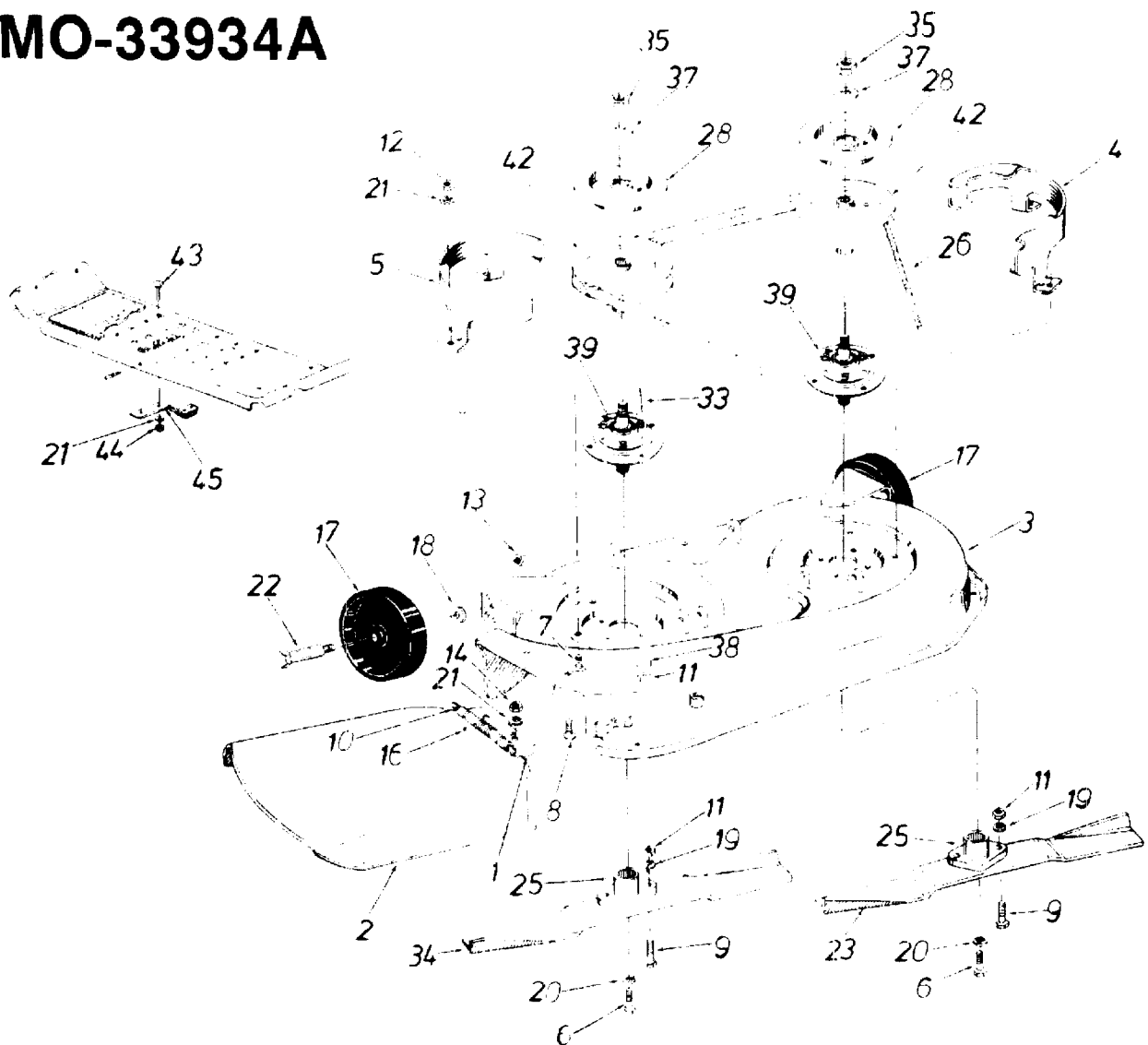

**14 H.P. 38" LAWN TRACTOR  
PARTS LIST FOR MODEL TMO-33934A**

REF. NO.	PART NO.	DESCRIPTION	NEW PART	REF. NO.	PART NO.	DESCRIPTION	NEW PART
1	16521	Chute Bracket		18	736-0105	Bell-Wash. .40" I.D. x .88" O.D.	
2	16566	Chute Deflector		19	736-0119	L-Wash. 5/16" I.D.*	
3	16575	38" Deep Deck Ass'y.		20	736-0217	L-Wash. 3/8" I.D.—H.D.	
	801-6576	38" Deep Deck Ass'y. Comp. (For Service Only)		21	736-0329	L-Wash. 1/4" I.D.*	
4	16607	Belt Guard Deck—L.H.		22	738-0373	Shld. Bolt .498" Dia. x 1.53"	
5	16608	Belt Guard Deck—R.H.		23	742-0472	High-Lift Blade—L.H.	
6	710-0152	Hex Bolt 3/8-24 x 1.00"		25	748-0300	Blade Adapter	
7	710-0195	Hex Bolt 1/4-28 x .62"		26	754-0329	5L V-Belt	
8	710-0255	Truss Mach. Scr. 1/4-20 x .75"		28	09322	Brake Disc	
9	710-0888	Hex Bolt Special 5/16-24 x 1.0"		33	710-1013	Rib Neck Bolt 5/16-24 x 1.05" Lg.	
10	711-0792	Hinge Pin		34	742-0473	High-Lift Blade—R.H.	
11	712-0123	Hex Nut 5/16-24 Thd.*		35	712-0318	Hex Jam Nut 5/8-18 Thd.	
12	712-0138	Hex Nut 1/4-28 Thd.		37	736-0158	L-Wash. 5/8" I.D.*	
13	712-0181	Hex Top L-Nut 3/8-16 Thd.		38	736-0119	L-Wash. 5/16" I.D.*	
14	712-0298	Hex Jam Nut 1/4-20 Thd.		39	717-0906	Blade Spindle Ass'y. Comp. (Incl. Ref. 33)	
16	732-0542	Torsion Spring		42	756-0486	5" Dia. Pulley	N
17	734-0973	Deck Wheel—5"					

# TMO-33934A

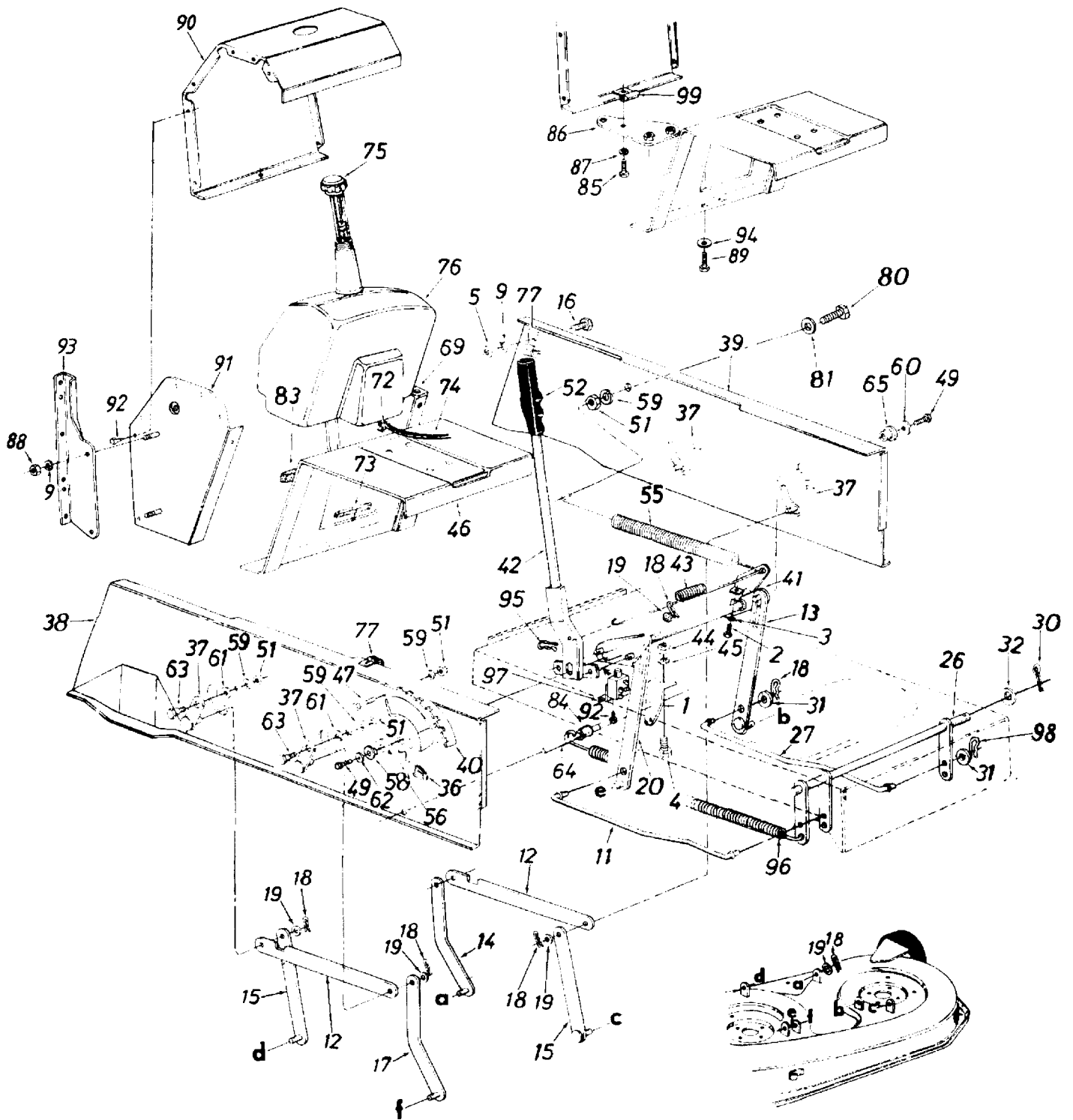



# TMO-33934A

## 14 H.P. 38" LAWN TRACTOR PARTS LIST FOR MODEL TMO-33934A

REF. NO.	PART NO.	DESCRIPTION	NEW PART	REF. NO.	PART NO.	DESCRIPTION	NEW PART
1	16181	Spring Hanger Bracket		56	732-0412	Deck Lift—Down Stop	
2	710-0602	Hex Tap. Scr. 5/16-18 x 1"		58	748-0176	Flange Brg. .630" I.D.	
3	712-3007	Hex Jam Nut 5/16-18 Thd.		59	736-0119	L-Wash. 5/16" I.D.*	
4	710-0258	Hex Bolt 1/4-20 x .62" Lg.*		61	736-0425	Bell-Wash. .325" I.D. x .930" x .045"	
5	712-0267	Hex Nut 5/16-18 Thd.*		62	736-0231	Fl-Wash. .344" I.D. x 1.125" O.D.	
8	732-0410	Ext. Spring 13.25" Lg.		63	738-0140	Shld. Bolt .437" Dia. x .180	
9	736-0119	L-Wash. 5/16" I.D.*		64	738-0526	Running Board Rod	
11	711-0790	Stabilizer Rod		65	741-0313	Flange Brg. .632" I.D.	
12	09735	Connecting Rod		69	17083	Side Panel—L.H.	
13	14802	Deck Lift Link Ass'y		71	710-0289	Hex Bolt 1/4-20 x .50" Lg.*	
14	15925	Deck Hanger Link Ass'y.—Rear L.H.		72	726-0207	Hose Clamp—.406" Dia.	
15	14804	Deck Hanger Link Ass'y.		73	731-0511	Trim Strip—5" Lg.	
16	710-0118	Hex Bolt 5/16-18 x .75" Lg.		74	751-0173	Gas Line—44" Lg.	
17	14800	Deck Hanger Link Ass'y.—(Dog Leg)		75	751-0226	Gas Tank Cap	
18	714-0101	Inter. Cotter Pin 1/2" Dia.		76	751-0403	Gas Tank	
19	736-0160	Fl-Wash. 531 I.D. x .93" O.D.		77	726-0175	Hose Clamp	
20	14802	Deck Lift Link Ass'y		80	710-0959	Hex Bolt 5/16-18 x 1.50" Lg.*	
26	16234	Stabilizer Shaft Ass'y.		81	736-0159	Fl-Wash. .344" I.D. x .875" O.D.	
27	711-0790	Stabilizer Rod		83	722-0157	Foam Strip 3/8" x 1-1/8" x 1 1/2" Lg. (2 Req'd.)	
30	714-0470	Cotter Pin 1/8" Dia. x 1.25" Lg.		84	711-0425	Spacer .523" I.D. x .640" O.D. x 1.95" Lg.	
31	736-0117	Fl-Wash. 385" I.D. x .620" O.D.		85	710-0376	Hex Bolt 5/16-18 x 1" Lg. Gr. 5	
32	736-0156	Fl-Wash. 635" I.D. x 1.12" O.D.		86	17166	Hitch Bar	
36	03540	Knob—Height Adj.		87	736-0119	L-Wash. 5/16" I.D.*	
37	09721	Pivot Link Ass'y		88	712-0267	Hex Nut 5/16-18 Thd.*	
38	14602	Side Panel Upper Frame—R.H.		89	710-0623	Self-Tap Scr. 3/4" Lg.	
39	14603	Side Panel Upper Frame—L.H.		90	16238	Gas Tank Housing	
40	16462	Index Brkt. (Deck Lift)		91	17082	Side Panel—R.H.	
41	17154	Lift Shaft Ass'y. (Incl. Ref. 2 & 3)		92	710-0351	Truss Mach. B-Tap Scr. #10 x .50" Lg.	
42	17194	Lift Handle Brkt. Ass'y.		93	17078	Mounting Bracket—R.H.	
43	732-0573	Ext. Spring			17077	Mounting Bracket—L.H. (Not Shown) (Use With Optional Grass Catcher)	
44	712-0287	Hex Nut 1/4-20 Thd.*		94	736-0105	Bell-Wash. 3/8" I.D.	
45	736-0329	L-Wash. 1/4" I.D.*		95	714-0145	Internal Cotter Pin 3/8" Dia.	
46	17226	Hitch Plate	N	96	732-0530	Ext. Spring 13.25" Lg.	
47	710-0118	Hex Bolt 5/16-18 x .75" Lg.*		97	725-0803	Safety Switch	
49	710-0604	Hex Wash. TT-Tap Scr. 5/16-18 x .62" Lg.		98	714-0111	Cotter Pin 3/32" Dia	
51	712-0267	Hex Nut 5/16-18 Thd.*		99	726-0211	Speed Nut	
52	720-0157	Grip					
55	732-0307	Ext. Spring 11" Lg.					

# TMO-33934A

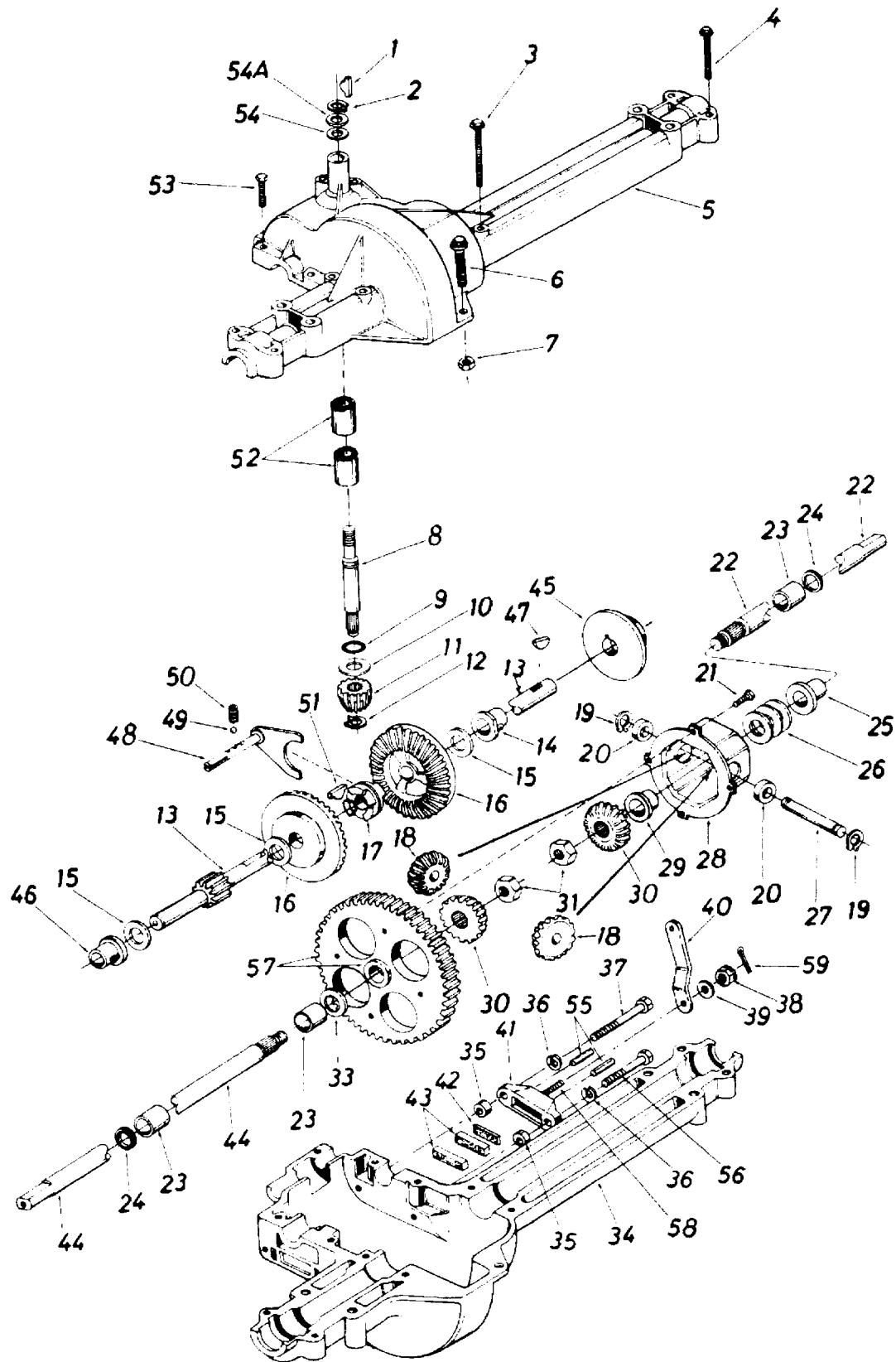

SINGLE SPEED TRANSAXLE—R.H.  
MODEL 717-1050

# TMO-33934A

## PARTS LIST FOR SINGLE SPEED TRANSAXLE RIGHT HAND 717-1050

REF. NO.	PART NO.	DESCRIPTION	NEW PART	REF. NO.	PART NO.	DESCRIPTION	NEW PART
1	714-0129	#4 Hi-Pro Key 3/32 x 5/8" Dia.		33	736-0351	Fl-Wash. .75" I.D. x 1.5" O.D.	
2	716-0115	Snap Ring .625" Shaft		34	717-0761	Lower Housing	
3	710-0854	Hex Bolt 1/4-20 x 1.75" Lg. *		35	750-0555	Spacer .53" O.D. x 3/8" Lg.	
4	710-0809	Hex Bolt 1/4-20 x 1.25" Lg. *		36	736-0329	L-Wash. 1/4" I.D. *	
5	717-0764	Upper Housing		37	710-0886	Hex Bolt 1/4-20 x 1.50" Lg. (Grade 5)	
6	710-0642	Hex Fl-Bolt 1/4-20 x .75" Lg		38	712-0335	Castle Nut 5/16-24 Thd. *	
7	712-0287	Hex Nut 1/4-20 Thd. *		39	736-0371	Fl-Wash. .34" I.D. x .875" O.D.	
8	717-0634	Input Shaft		40	717-0700	Actuating Arm—R.H.	
9	721-0178	Square Seal 5/8" I.D.		41	717-0679	Brake Yoke	
10	736-0335	Thrust Washer 5/8" I.D. x 1.25" O.D.		42	717-0682	Puck Plate	
11	717-0633	Pinion Input 14T		43	717-0678	Brake Puck	
12	716-0108	Retaining Ring 7/16" Ext.		44	717-1011	Axle L.H.	
13	717-0758	Drive Shaft—R.H.		45	717-0677	Brake Disc	
14	741-0336	Flange Brg. 5/8" I.D. x 3/4" Lg. *		46	741-0337	Flange Bearing 5/8" I.D. x 15/16" Lg.	
15	**	Fl-Wash. (See Below)		47	714-0161	Woodruff Key 3/16 x 5/8 HT	
16	717-0757	Bevel Gear 42T		48	717-0754	Shift Fork Ass'y.	
17	717-0667	Clutch Collar		49	741-0862	Ball Detent 250" Dia.	
18	717-1020	Miter Gear 15T—H.D.		50	732-0863	Spring Detent	
19	716-0142	Snap Ring		51	714-0169	#9 Hi-Pro Key 3/16" x 3/4" Dia. HT	
20	717-0690	Thrust Bearing 1/2" I.D. x 1.0" O.D.		52	741-0335	Needle Brg. 5/8" I.D. x 1/2" Lg.	
21	710-0862	Pan Head Scr. 1/4-20 x .50" Lg. w/Patch		53	710-0855	Hex Bolt 1/4-20 x 1.00" Lg.	
22	717-1012	Axle R.H.		54	736-0336	Fl-Wash. 5/8" I.D. x .030	
23	741-0340	Sleeve Bearing 3/4" I.D. x 1.0" Lg.		54A	736-0337	Fl-Wash. 5/8" I.D. x .040	
24	721-0179	Oil Seal 3/4" I.D.		54B	736-0349	Fl-Wash. 5/8" I.D. x .020	
25	741-0339	Flange Bearing 3/4" I.D. x 15/16" Lg.		55	741-0343	Actuating Pin 5/16" Dia.	
26	736-0188	Fl-Wash. .760" I.D. x 1.49" O.D.		56	710-0886	Hex Bolt 1/4-20 x 1.50" Lg. (Grade 5)	
27	717-0673	Cross Shaft		57	717-1059	Differential Gear 72T Ass'y. w/Bearing	
28	717-0777	Differential Housing Ass'y.		58	717-0796	Sq. Hd. Bolt 5/16-24 Thd.	
29	—	Comes with Ref. 28		59	1544-013	Cotter Pin 3/32" Dia. x .50" Lg.	
30	717-1019	Miter Gear—H.D.		—	737-0148	Grease—Shell (10 oz.)	
31	712-0200	Hex Ins. L-Nut 1/2-20 Thd.					

\*\*Ref. No. 15 736-0349 Fl-Wash. 5/8" I.D. x 1.0" O.D. x .020 Thk.  
736-0336 Fl-Wash. 5/8" I.D. x 1.0" O.D. x .030 Thk.  
736-0337 Fl-Wash. 5/8" I.D. x 1.0" O.D. x .040 Thk.

At the time of manufacture of lawn tractor, the optional accessories listed below are available.

Description	Stock No.
36" Snow Thrower	89-33848R
42" Snow Blade	89-33879R
Grass Collector	89-35108R
38" Lawn Sweeper	89-37952R
30 Lb. Wheel Weights	89-33862R
Gang Reel	89-27R

## SERVICE NATIONWIDE

# Montgomery Ward

### HOW TO OBTAIN REPLACEMENT PARTS AND SERVICE

The merchandise you have purchased from us has been carefully engineered and manufactured under Montgomery Ward's rigid quality standards and should give you satisfactory and dependable operation. However, like all mechanical merchandise, it may occasionally require adjustment, replacement parts or maintenance.

#### **Toll Free Parts Sales Center**

When you need a replacement part or accessory for a major appliance, home electronic item or lawn and garden product that is not under warranty or covered by a service contract or if you need the location of the nearest service facility, call our Parts Sales Center toll free 1-800-323-1965.

#### **Provide the following:**

1. Model, serial number and all of the other data shown on the model plate.
2. Also give the part number or numbers as shown in the parts list that came with the product.

Replacement Parts will be made available at current prices. If requested, prices will be quoted in advance when not listed.

If you order parts by mail, you will pay the transportation charges from the shipping point.

UNIT MODEL NO. \_\_\_\_\_

UNIT SERIAL NO. \_\_\_\_\_

ENGINE MODEL NO. \_\_\_\_\_

TYPE NO. \_\_\_\_\_

CODE NO. \_\_\_\_\_